



Monoblock heat pump water heater with domestic hot water storage tank with or without solar exchanger

GREEN 200 R290 - GREEN 200 S R290

GREEN 300 R290 - GREEN 300 S R290



TABLE OF CONTENT

INTRODUCTION.....	2
This manual.....	2
The unit.....	2
SAFETY INSTRUCTIONS.....	3
Warning.....	3
Caution.....	5
ITEMS INSIDE PRODUCT BOX.....	6
OVERVIEW OF THE UNIT.....	7
Parts and descriptions.....	7
Dimensions.....	8
How to replace the magnesium anode.....	9
Schematic overview of the water and refrigeration circuit.....	9
INSTALLATION.....	10
Transportation.....	10
Required service space.....	11
Installation overview.....	12
Installation positions.....	15
Water loop connection.....	16
Water affusion and water emptying.....	16
Wire connection.....	17
Trial running.....	17
OPERATION THE UNIT.....	18
User interface and operation.....	18
LED icons.....	21
PARAMETER CHECKING AND ADJUSTMENT.....	23
Parameter list.....	23
Malfunctioning of the unit and error codes.....	26
MAINTENANCE.....	28
TROUBLESHOOTING.....	29
ENVIRONMENTAL INFORMATION.....	29
DISPOSAL REQUIREMENTS.....	30
WIRING DIAGRAM.....	30
TECHNICAL SPECIFICATION.....	31
Noble Air 200/300	32
TEMPERATURE SENSOR R-T CONVERSION TABLE.....	32



READ THIS MANUAL CAREFULLY BEFORE STARTING UP THE UNIT. DO NOT THROW IT AWAY.KEEP IT IN YOUR FILES FOR FUTURE REFERENCE.



BEFORE OPERATING THE UNIT, MAKE SURE THE INSTALLATION HAS BEEN CARRIED OUT CORRECTLY BY A PROFESSIONAL DEALER. IF YOU FEEL UNSURE ABOUT OPERATION, CONTACT YOUR DEALER FOR ADVICE AND INFORMATION.

INTRODUCTION

This manual

This manual includes the necessary information about the unit. Please read this manual carefully before you use and maintain the unit.

The unit

The hot water heat pump is one of the most economical systems to heat the water for family domestic use. Using free renewable energy from the air, the unit is highly efficient with low running costs. Its efficiency can be up to 3 ~ 4 times more than conventional gas boilers or electrical heaters.

Waste Heat recovery

Units can be installed near the kitchen, in the boiler-room or the garage, basically in every room which has a large number of waste-heat so that the unit has the higher energy efficiency even with very low outside temperatures during the winter.

Hot water and dehumidification

Units can be placed in the laundry room or clothing room. When it produces hot water it lowers the temperature and dehumidifies the room as well. The advantages can be experienced particularly in the humid season.

Storage room cooling

Units can be placed in the storage room as the low temperature keeps the food fresh.

Hot water and fresh air ventilation

Units can be placed in the garage, gym, basement etc. When it produces hot water, it cools the room and supplies fresh air.

Compatible with different energy sources

Units can be compatible with solar panels, external heat pumps, boilers or other different energy sources.

Ecological and Economical Heating

Units are the most efficient and economical alternative to both fossil fuel boilers and heating systems. By making use of the renewable source in the air, it consumes much less energy.

Compact design

Units are especially designed for offering sanitary hot water for family use. Its extremely compact structure and elegant design are suitable for indoor installation.

Multiple Functions

The special design of the air inlet and outlet makes the unit suitable for various ways of connections. With

different ways of installation, the unit can work as just a heat pump but also as a fresh air blower, a dehumidifier, or an energy recovery device.

Other features

Stainless steel tank and a magnesium stick assure the durability of components and the tank.

Highly efficient compressor with the R290 refrigerant.

Electrical element available in the unit as a back-up, assuring constant hot water even in extreme cold winters.

SAFETY INSTRUCTIONS

To prevent injury to the user, other people, or property damage, the following instructions must be followed. Incorrect operation due to ignoring of instructions may cause harm or damage.

Install the unit only when it complies with local regulations, by-laws and standards. Check the main voltage and frequency. This unit is only suitable for earthed sockets, connection voltage 220 – 240 V ~ / 50Hz.

The following safety precautions should always be taken into account:

- Be sure to read the following WARNING before installing the unit.
- Be sure to observe the cautions specified here as they include important items related to safety.
- After reading these instructions, be sure to keep it in a handy place for future reference.

Warning



Do not install the unit yourself.

Incorrect installation could cause injury due to fire, electric shock, the unit falling or leakage of water. Consult the dealer from whom you purchased the unit or a specialized installer.

Install the unit securely in a place.

When insufficiently installed, the unit could fall causing injury. The bearing surface should be flat to bear the weight of the unit and suitable for installing the unit without increasing noise or vibration. When installing the unit in a small room, please take measures (like sufficient ventilation) to prevent the asphyxia caused by the leakage of refrigerant.

Use the specified electrical wires and attach the wires firmly to the terminal board (connection in such a way that the stress of the wires is not applied to the sections).

Incorrect connection and fixing could cause a fire.

Be sure to use the provided or specified parts for the installation work.

The use of defective parts could cause an injury due to possible fire, electric shocks, the unit falling etc.

Perform the installation securely and please refer to the installation instructions.

Incorrect installation could cause an injury due to possible fire, electric shocks, the unit falling, leakage of water etc.

Perform electrical work according to the installation manual and be sure to use a dedicated section, fused with 16A.

If the capacity of the power circuit is insufficient or there is an incomplete electrical circuit, it could result in a fire or an electric shock.

The unit must always have an earthed connection.

If the power supply is not earthed, you may not connect the unit.

Never use an extension cable to connect the unit to the electric power supply.

If there is no suitable, earthed wall socket available, have one installed by a recognized electrician.

Do not move/repair the unit yourself.

If the supply cord is damaged, it must be replaced by the manufacturer or its service agent or a similarly qualified person in order to avoid a hazard. Improper movement or repair on the unit could lead to water leakage, electrical shock, injury or fire.

The unit is no intended for use by children.

This appliance is not intended for use by persons (including children) with reduced physical, sensory or mental capabilities, or lack of experience and knowledge, unless they have been given supervision or instruction concerning use of the appliance by a person responsible for their safety.

Children should be supervised to ensure that they do not play with the appliance.

Do not tear off the labels on the unit.

The labels are for the purpose of warning or reminding, keeping them can ensure your safe operations.

Caution



Do not install the unit in a place where there is a chance of flammable gas leaks.

If there is a gas leak and gas accumulates in the area surrounding the unit, it could cause an explosion.

Perform the drainage/piping work according to the installation instruction.

If there is a defect in the drainage/piping work, water could leak from the unit and household goods could get wet and be damaged.

Do not clean the unit when the power is 'ON'.

Always shut 'OFF' the power when cleaning or servicing the unit. If not, it could cause an injury due to the high speed running fan or an electrical shock.

Do not continue to run the unit when there is something wrong or there is a strange smell.

The power supply needs to be shut 'OFF' to stop the unit; otherwise this may cause an electrical shock or fire.

Do not put your fingers or others into the fan, or evaporator.



The inside parts of the heat pump may run at high speed or high temperature, they could cause serious injury. Do not remove the grills on the fan outlet and top cover.

The hot water probable need to mix with cold water for terminal usage, too hot water (over 50°C) in the heating unit may cause injury.

The installation height of power supply should be over 1.8m, if any water may spatter, the unit can be safe from water.

ITEMS INSIDE PRODUCT BOX

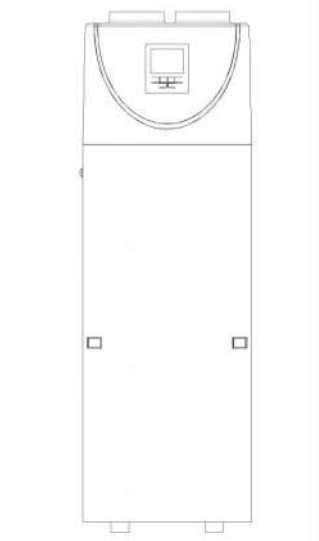
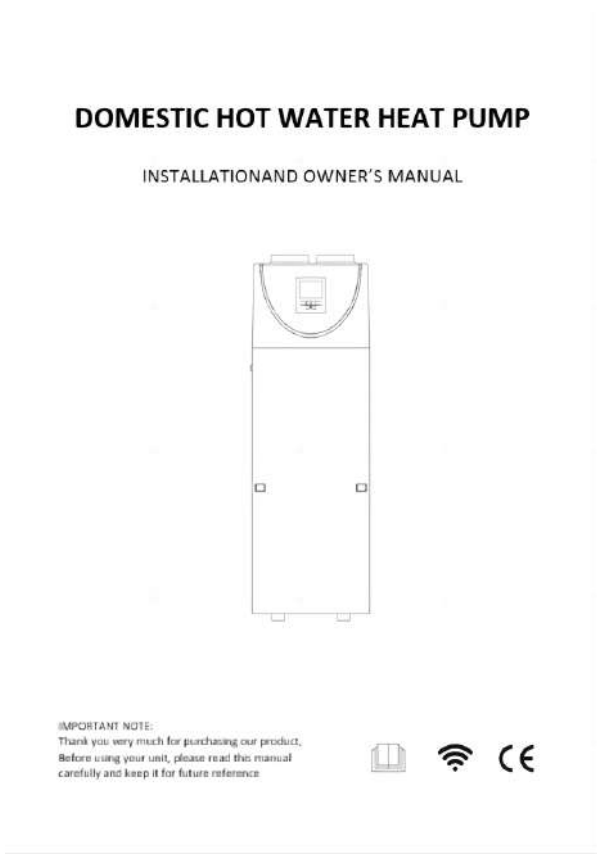
Before starting the installation, please make sure that all parts are found inside the box.

The Unit Box		
Item	Image	Quantity
Domestic hot water heat pump		1
Operation & Installation Manual	<p style="text-align: center;">DOMESTIC HOT WATER HEAT PUMP</p> <p style="text-align: center;">INSTALLATION AND OWNER'S MANUAL</p>  <p><small>IMPORTANT NOTE: Thank you very much for purchasing our product, Before using your unit, please read this manual carefully and keep it for future reference</small></p> 	1

OVERVIEW OF THE UNIT

Parts and descriptions

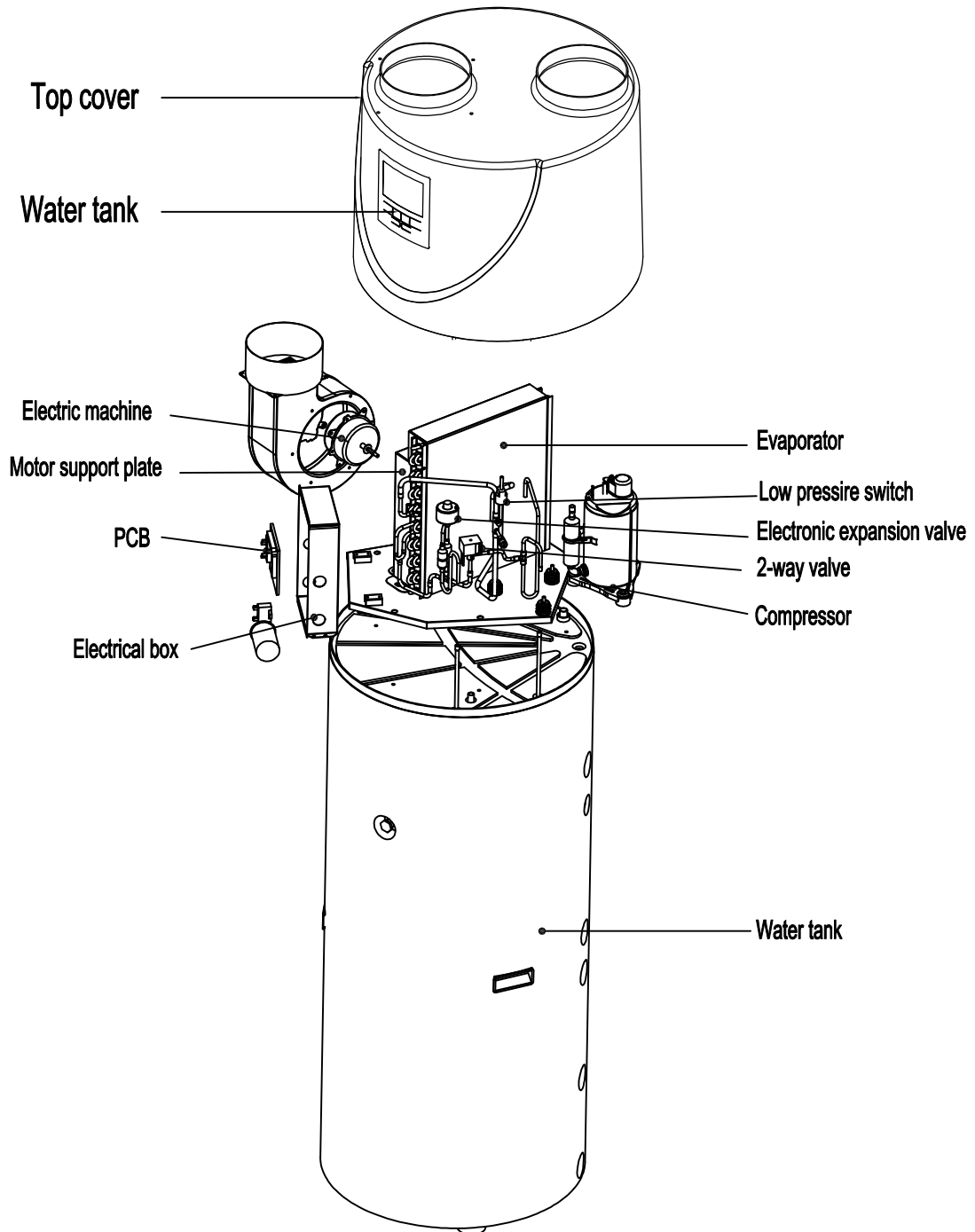

Dimensions

Model: 200/300

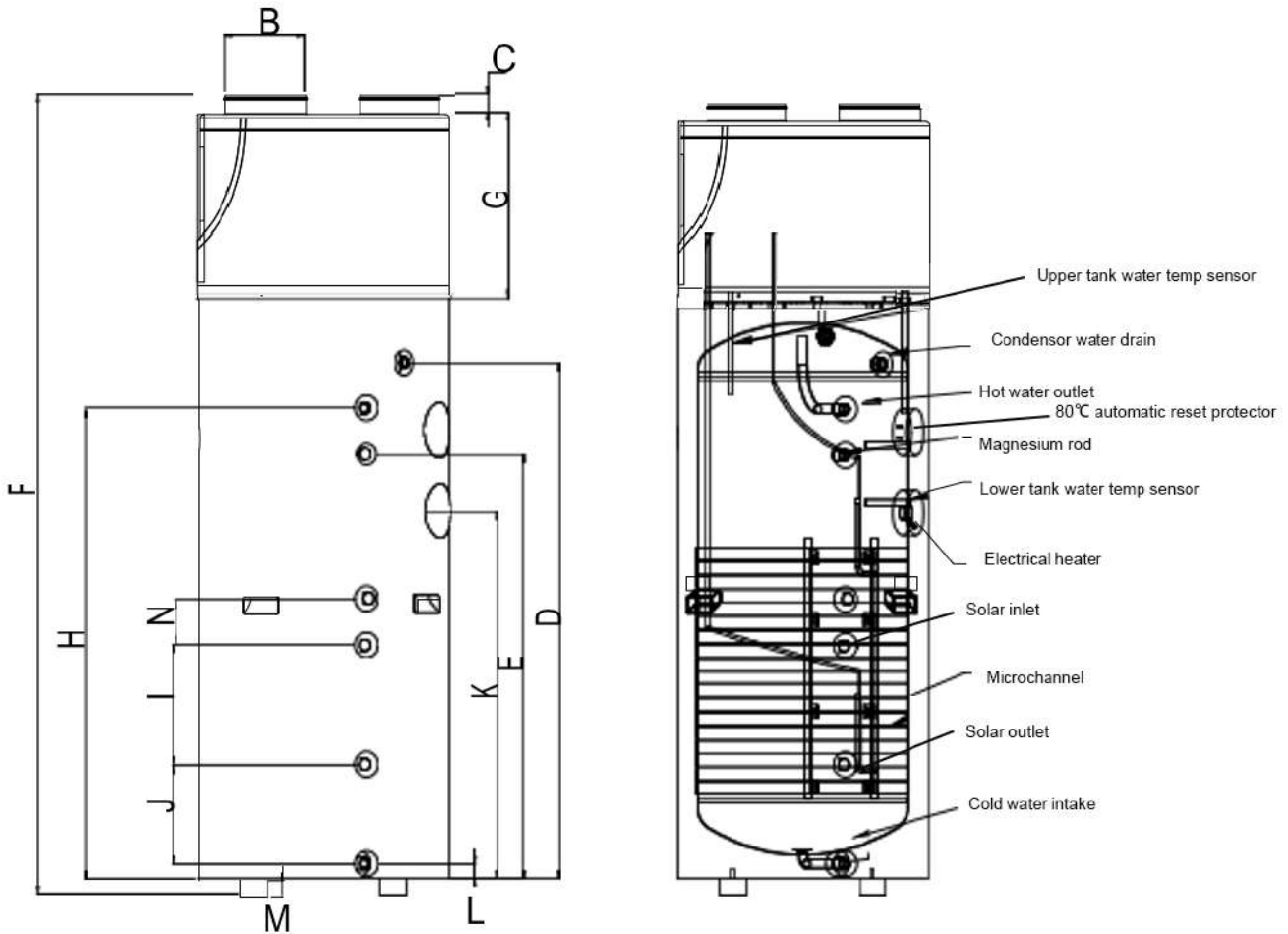

	200L\200Ls	300L\300Ls
A	Φ560	Φ600
B	177	177
C	40	40
D	1125	1370
E	925	1170
F	1745	1990
G	445	445
H	1025	1270
I	-\260	-\620
J	-\218	-\202
K	800	950
L	32.5	32.5
N	-\100	-\100
M	35	35

Remark:

1) The extra heat source is optional.

2) The Magnesium stick is an anti-corrosion element. It is assembled in the water tank to avoid the creation of fur around the inside tank and to protect the tank, and other components. It can help to extend the life-span of the tank. **Check the magnesium stick every half year and change it if it has been used out !**

How to replace the magnesium anode  :

- Turn the power of the unit 'OFF' and pull out the plug.
- Drain all the water out of the tank.
- Remove the old magnesium anode from the tank.
- Replace the new magnesium anode.
- Recharge the water.

Schematic overview of the water and refrigeration circuit

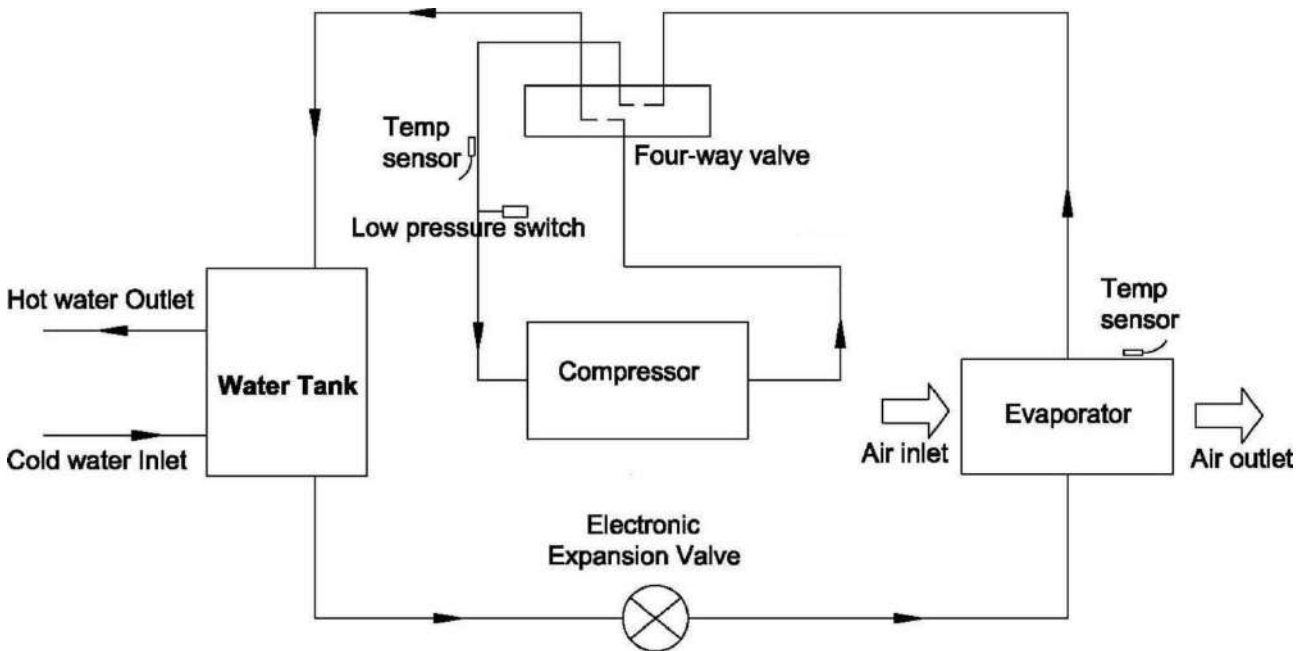

Choose the suitable unit

Please refer to the table below to choose the suitable unit.

Family members	Tank capacity
4 ~ 5 people	200L
More than 6 people	300L

Note: The table is just for reference.

INSTALLATION

WARNING

- Asked your supplier to install the unit. Incomplete installation performed by yourself may result in a water leakage, electric shock, or fire.
- Indoor installation is highly recommended. It is not allow to install the unit at outdoor or rain achieving place.
- The installation place without direct sunlight and other heat supplies is recommended. If no way to avoid these, please install a covering.
- The unit must be securely fixed to avoid noise and shaking.
- Make sure that there's no remora around the unit.
- In the place where there is strong wind, fix the unit in the location protected from the wind.

Transportation

As a rule, the unit is to be stored and/or transported in its shipping container in upright position and without water charge. For a transport over short distance (provided that it is done with care), an inclination angle up to 30 degrees is permitted, both during transport and storage. Ambient temperatures of -20 to $+70$ degrees Celsius are permitted.

- **Transport using a forklift**

When transported by a forklift, the unit must remain mounted on the pallet. The lifting rate should be kept to a minimum. Due to its top-heaviness, the unit must be secured against tipping over. To prevent any damage, the unit must be placed on a level surface.

- **Manual transport**

For the manual transport, a wooden/plastic pallet can be used. Using ropes or carrying straps, a second or third handling configuration is possible. With this type of handling, it is advised that the maximum permissible inclination angle of 45 degree is not exceeded. If transport in an inclined position cannot be avoided, the unit should be taken into operation one hour after it has been moved into final position.

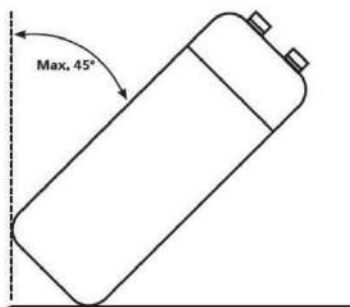

ATTENTION: DUE TO THE HIGH CENTER OF GRAVITY, LOW OVERTURNING MOMENT, THE UNIT MUST BE SECURED AGAINST TIPPING OVER.

Required service space

Below you will find the minimum space required to be able to complete service and maintenance tasks on the units.

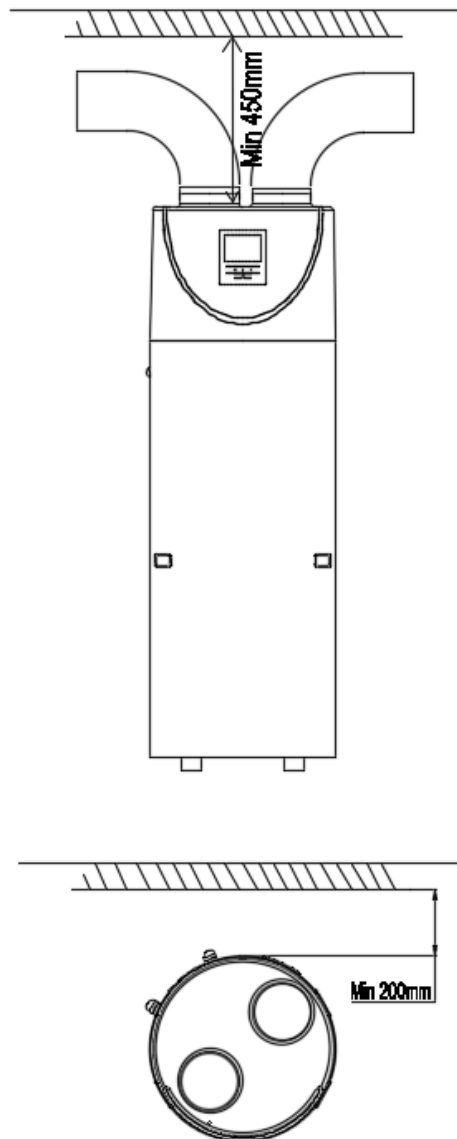

Note:

- If air inlet and/or outlet pipes are connected, portion airflow and capacity in heat pump unit will lose.
- If the unit connects with air ducts it should be **DN 180mm** for pipes or 180mm internal diameter flexible hose. Total length of the ducts should not be longer than 8m or the maximum **static pressure should not exceed** than **60Pa**. Be in mind of bending site of the duct no more than 4m. An unsuitable type of ducting penalizes the performance of the product and significantly increases the heating time.
- If the installation room has a volume of more than **30 m³**, the installation of the above-mentioned air ducts can be avoided, except for the two supply/return air separation elbows with a diameter of 180 mm, which must always be provided. Respect distances from walls.

Installation overview

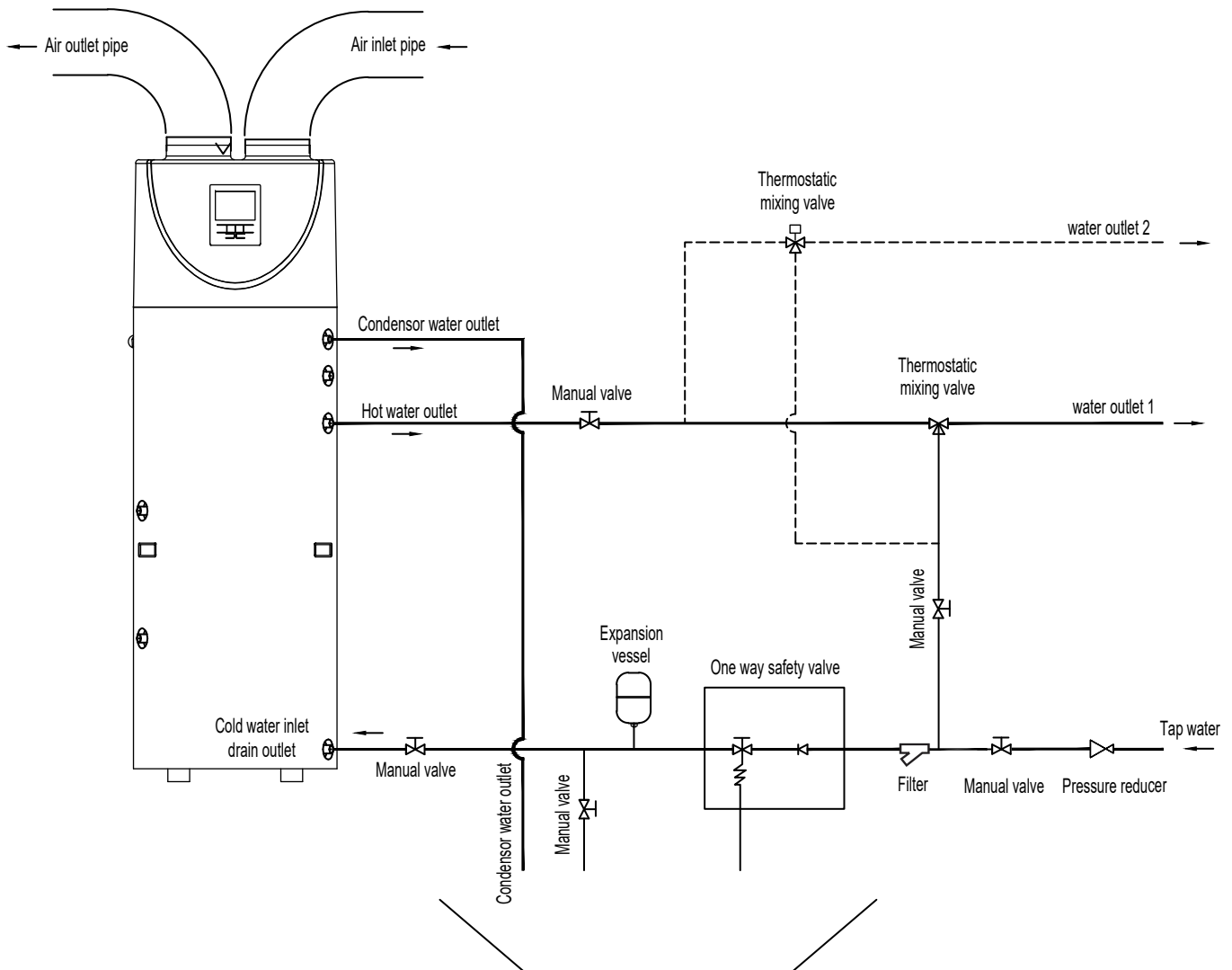

- Note:** - It is necessary add an **expansion vessel** according to the tank capacity;
 - It is necessary install a **safety valve** for pressure and temperature;
 - It is necessary install a **pressure reducer**;
 - It is necessary install a **water treatment devices** (softener,filter etc.);

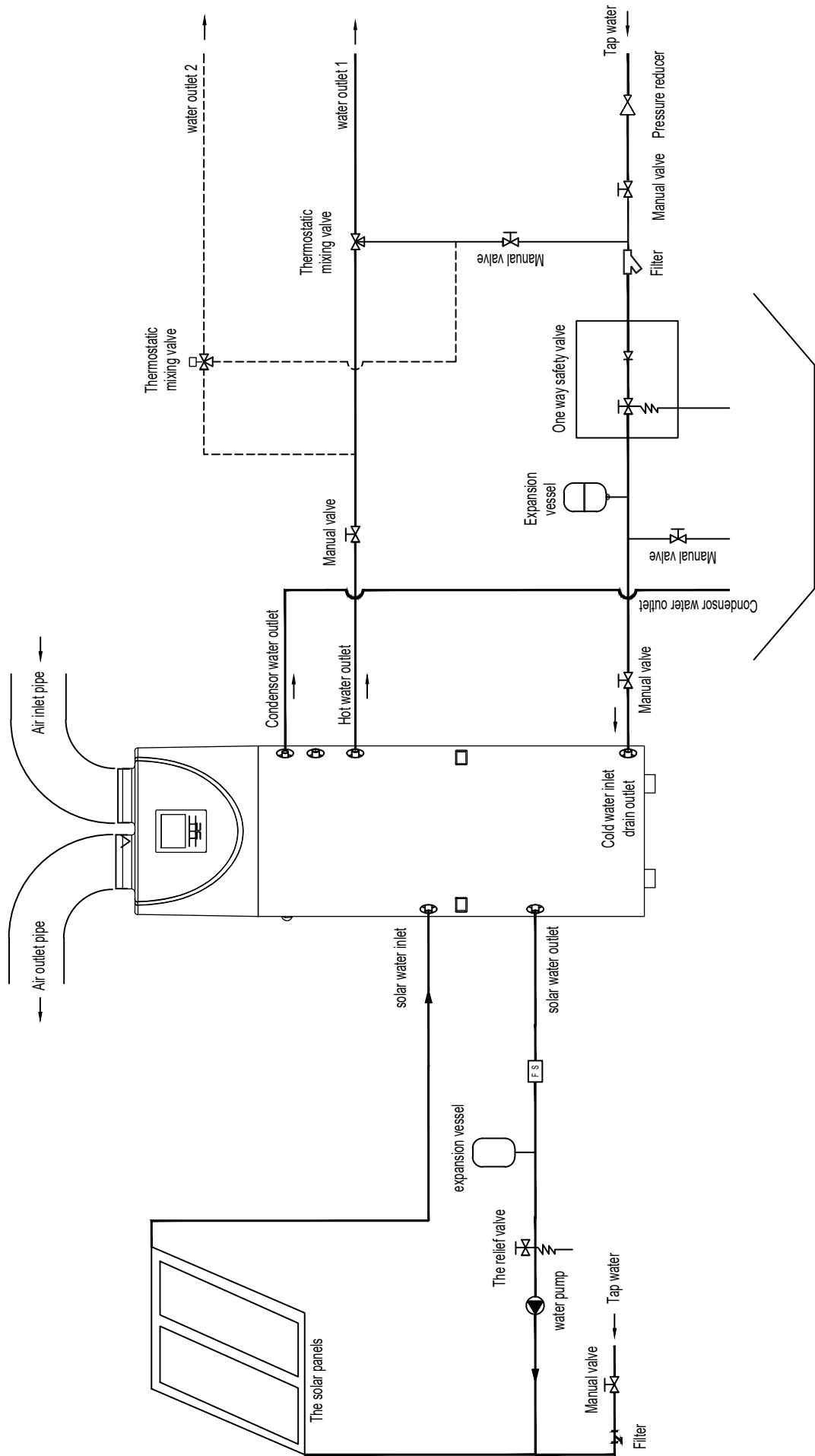



ATTENTION:

- The one-way safety valve must be installed. If not, it could cause damage to the unit, or even hurt people. The set point of this safety valve is 0.7 MPa. For the installation place please refer to the pipeline connection sketch.
- The discharge pipe connected to the one-way safety valve is to be installed in a continuously downward direction and in a frost-free environment.
- The water may drip from the discharge pipe of the one-way safety valve and that this pipe must be left open to the atmosphere.
- The one-way safety valve is to be operated regularly to remove lime deposits and to verify that it is not blocked. Please beware of burn, because of the high temperature of water.
- The tank water can be drained through the drainage hole on the bottom of the tank.
- After all the pipes installed turn on the cold water inlet and hot water outlet to fill the tank. When there is water normally following out from water outlet, the tank is full. Turn off all valves and check all pipes. If any leakage, please repair.
- If the inlet water pressure is less than 0.15MPa, a pressure pump should be installed at the water inlet. For ensure the long safety using age of tank at the condition of water supply hydraulic higher than 0.65MPa, a reducing valve should be mounted at the water inlet pipe.
- Filters are needed in the air inlet. If the unit is connected with ducts, filter in there must be put forward to the air inlet of duct.
- To fluently drain condensate water from evaporator, please install the unit at the horizontal floor. Otherwise, please make sure the drain vent is at the lowest place. Recommending the inclination angle of unit to be ground should no more than 2 degree.

Installation positions

(1) Waste heat can be useful heat

Units can be installed near the kitchen, in the boiler-room or the garage, basically in every room which has a large number of waste-heat so that the unit has the higher energy efficiency even with very low outside temperatures during the winter.



(2) Hot water and dehumidification

Units can be placed in the laundry room or clothing room. When it produces hot water it lowers the temperature and dehumidifies the room as well. The advantages can be experienced particularly in the humid season.



(3) Solar panel or external heat pump could be the second heat source

Units can work with solar panel, external heat pump, boiler or other different energy source.

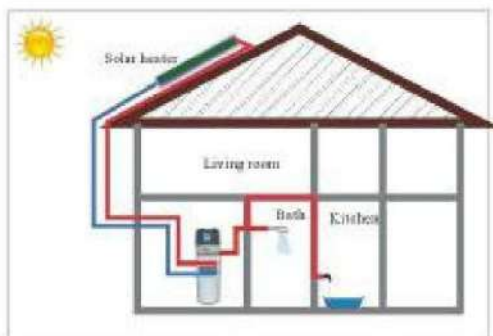

NOTE:

- Choose the right path to move the unit.
- This unit complies with the relevant technical standards of electrical equipment.

Water loop connection

Please pay attention to the below points when connecting the water loop pipe:

1. Try to reduce the water loop resistance
2. Make sure there is nothing in the pipe and the water loop is smooth, check the pipe carefully to see if there is any leak, and then pack the pipe with the insulation.
3. Install the one way valve and safety valve in the water circulation system.
4. The nominal pipe wide of the field- installed sanitary installations must be selected on the basis of the available water pressure and the expected pressure drop within the piping system.
5. The water pipes may be of the flexible type. To prevent corrosion damage, make sure that the materials used in the piping system are compatible.
6. When installing the pipe-work on the customers' site, any contamination of the piping system must be avoided.

Water affusion and water emptying

Water Affusion:

If the unit is used for the first time or used again after emptying the tank, please make sure that the tank is full of water before turning on the power.

- Open the cold water inlet and hot water outlet.
- Start the water affusion. When there is water normally flowing out from the hot water outlet, the tank is full.
- Turn off the hot water outlet valve and water affusion is finished.



ATTENTION: Operation without water in water tank may result in damage of auxiliary e-heater!

Water emptying:

If the unit needs cleaning, moving etc, the tank should be emptied.

- Close the cold water inlet
- Open the hot water outlet and open the manual valve of drainpipe
- Start the water emptying.
- After emptying, close the manual valve.

Wire connection

- . The specification of the power supply wire is 3*1.5 mm².
- . Fuse specification is T 3.15A 250V
- . There must be a switch when connecting the unit to the power system. The current of the switch is 10A.
- . The unit must be installed a Creepage Breaker near the power supply and must be effectively earthed. The specification of the creepage breaker is 30mA, less than 0.1sec.

THE APPLIANCE SHALL BE INSTALLED IN ACCORDANCE WITH NATIONAL WIRING REGULATIONS.

Trial running

Checks before trial running

- . Check both the water in the tank as well as the water pipe connection.
- . Check the power system, make sure that the power supply is normal and the wire connection is ok.
- . Check the inlet water pressure, and make sure that the pressure is sufficient (above 0.15Mpa).
- . Check if any water flows out from the hot water outlet, and make sure that the tank is full of water before turning on the power.
- . Check the unit; make sure everything is ok before turning 'ON' the power of the unit, check the light on the wire controller when the unit runs.
- . Use the wire controller to start the unit.
- . Listen to the unit carefully when turning 'ON' the power of the unit. Turn the power 'OFF' when you hear an abnormal sound.
- . Measure the water temperature, to check the undulation of the water temperature.
- . Once the parameters have been set, the user cannot change the parameters optionally. Please use a qualified service person to do this.

OPERATION THE UNIT

User interface and operation

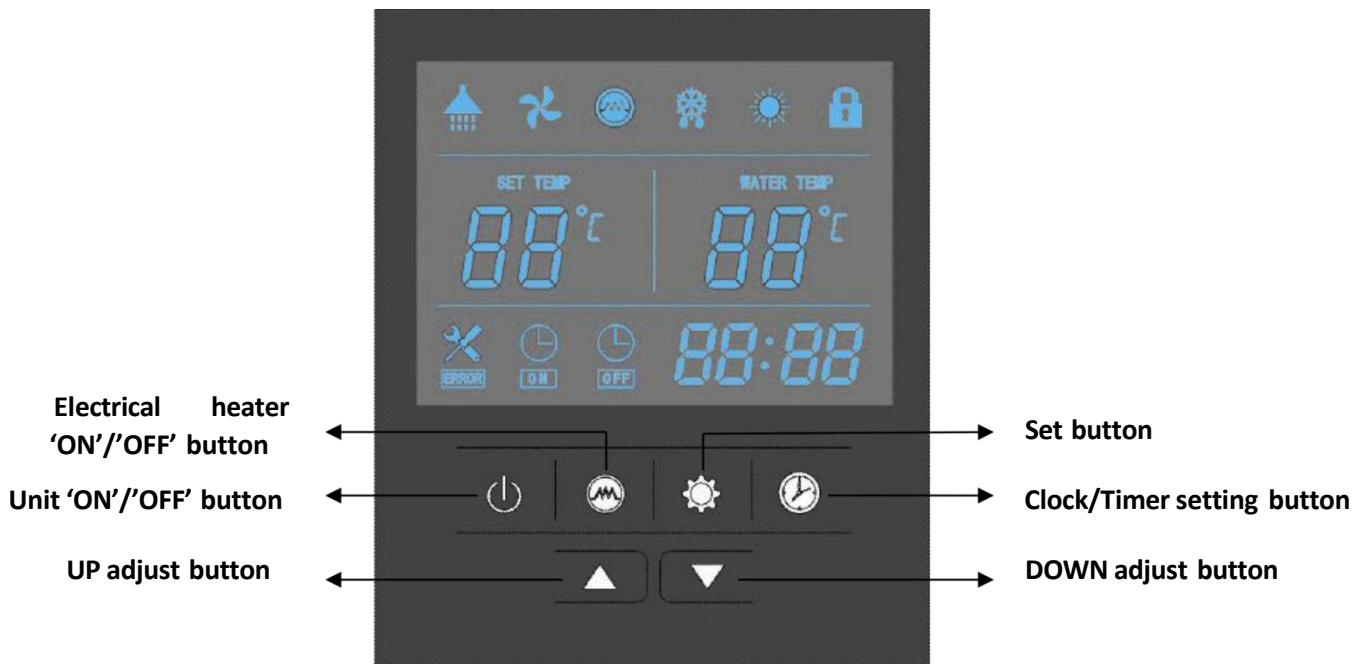

Operations

1. Power 'ON'

When turning 'ON' the power, whole icons are displayed on the controller screen for 3 seconds. After checking if everything is ok, the unit enters into the standby mode.

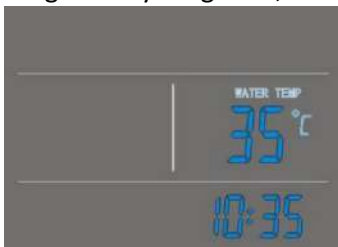

2. button

Press this button and keep for 2 seconds when the unit is standby, the unit can be turned 'ON'. Press this button and keep for 2 seconds when the unit is running, the unit can be turned 'OFF'. Short press this button to entry or exit the parameter setting or checking.





3. ▲ And ▼ buttons







- These are the multi-purpose buttons. They are used for the temp setting, parameter setting, parameter checking, clock adjustment and adjustment of the timer.
- During running status, press ▲ or ▼ button to adjust the setting temperature directly.
- Press these buttons when the unit is on clock setting status, the hour(s) and the minute(s) of the clock time can be adjusted.
- Press these buttons when the unit is on timer setting status, the hour(s) and the minute(s) of the timer 'ON'/'OFF' can be adjusted.
- Press ▲ and ▼ buttons at the same time and hold for 5 seconds, the buttons are locked.
- Press ▲ and ▼ buttons at the same time and hold for 5 seconds again, the buttons are unlocked.

4. button

Clock setting:

- After power on, short press  button to enter the clock setting interface, hour and minute icons "88:88" flash together;
- Short press  button to switch hour/minute setting, press the ▲ and ▼ buttons to set the exact hour(s) and minute(s);
- Press  button again to confirm and exit.

Timer setting:

- After power on, long press  button for 5 seconds to enter the timer setting interface, the timer on icon  and hour icon "88:" flash together;
- Press the ▲ and ▼ buttons to set the exact hour(s).
- Press  button to transfer to minute setting, minute icon ":88" flash, press the ▲ and ▼ buttons to set the exact minute(s).
- Press  button again to transfer to timer off setting, the timer off icon  and hour icon "88:" flash together.
- Press the ▲ and ▼ buttons to set the exact hour(s).
- Press  button to transfer to minute setting, minute icon ":88" flash, press the ▲ and ▼ buttons to set the exact minute(s).
- Press  button again to save and exit the timer setting interface.

Press  button to cancel the timer settings during the timer 'ON' (or timer 'OFF') programming.

NOTE:







- 1) The timer 'ON' and timer 'OFF' functions can be set at the same time.
- 2) The timer settings are repeating.
- 3) The timer settings are still valid after a sudden power cut.

5. button

- 1) When the heat pump is ON, press this button to turn 'ON' the electrical heater. The heater icon  will be showed, and the electrical heater will work according to the control program (parameter 3).
- 2) When the heat pump is ON, press this button and hold for 5 seconds to enable or disable the fan ventilation function.
- 3) When the heat pump is OFF, press this button to entry E-heater heating mode.

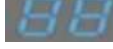
6. button

- 1) Check the temperatures and EXV open steps
-Short press this button to entry temp and EXV open step checking.
-Press the ▲ and ▼ buttons to check the temp sensor values and EXV open steps (parameters A-F).
- 2) Check the system parameters
-In any status, press this button and hold for 5 seconds, entry the system parameter checking interface.
-Press the ▲ and ▼ buttons to check the system parameters.
- 3) Adjust the system parameters
-Manufacturer parameters (password 76 or 29)

When the unit is off, press  and  2s to enter the password, water temp area  blinking(only 00 display),press "  " to enter the password "7", press "  "again to enter password "6" , then press "  " to confirm(If the password is wrong, it will return to home page,Enter another password)

After entering parameter modify page, press " ▼ " " ▲ " to select the parameter need to be modified.

Press "  " to confirm the selection, press " ▲ " " ▼ " to modify the parameter. Press "  " to confirm the modification and return to home page

NOTE: The parameters have been set; the user cannot change the parameters optionally. Please ask a qualified service person to do this when required.

7. Error codes

During standby or running status, if there is a malfunction, the unit will stop automatically and show the error code on the left screen of the controller.



LED icons

1. Hot water available

The icon indicates that the domestic hot water temperature reaches the set point. The hot water is available for use. Heat pump is standby.

2. Fan ventilation

The icon indicates that the fan ventilation function is enabled.

When the unit is on, press the  button and hold it for 5 seconds the fan ventilation function can be enabled or disabled. If this function is enabled the fan will continue working to ventilate the air, when the water temperature reaches the set point and unit is standby. If this function is disabled the fan will stop, when the water temperature reaches the set point and unit is standby.

3. Electrical heating

The icon indicates that the electrical heating function is enabled. The electrical heater will work according to the control program.

4. Defrosting

This icon shows the heat pump is under defrosting

5. Heating

This icon shows the heat pump is working

6. Key lock

The icon indicates the key lock function is enabled. The keys cannot be operated until this function is disabled.

7. Left temperature display

The display shows the setting water temperature.

When checking or adjusting the parameters, this section will display the relating parameter number.

8. Right temperature display

The display shows the current upper water tank temperature.

When checking or adjusting the parameters, this section will display the related parameter value.
In case any malfunction occurs, this section will display the related error code.

9. Time display 

The display shows the clock time or timer time.

10. Timer 'ON' 

The icon indicates that the timer 'ON' function is enabled.

11. Timer 'OFF' 

The icon indicates that the timer 'OFF' function is enabled.

12. Error 

The icon indicates there is malfunction.

PARAMETER CHECKING AND ADJUSTMENT

Parameter list

Some parameters can be checked and adjusted by the controller. Below is the parameter list.

Parameter No.	Description	Range	Default	Remarks
0	Tank water setting temp.	35~ 65°C	55°C	Adjustable
1	Lower water tank temp and the setting temperature difference	2 ~ 15°C	5°C	Adjustable
2	E-heater off tank water temp	35~70°C	65°C	Adjustable
3	E-heater delay time	0 ~ 90 min	6 min	t * 5 min
4	Weekly disinfection temperature	50~65°C	65°C	Adjustable
5	High temp disinfection time	0 ~ 90 min	30 min	Adjustable
6	Defrosting period	30~90 min	45 min	Adjustable
7	Defrosting entry coil temp.	-30 ~ 0°C	-7°C	Adjustable
8	Defrosting exit coil temp.	2 ~ 30°C	13°C	Adjustable
9	Max defrosting cycle time	1 ~ 12 min	8 min	Adjustable
10	Electronic expansion valve adjustment	1=auto 0>manual	1	Adjustable
11	Target over-heat degree	-9~20°C	4°C	Adjustable
12	Steps of manually adjusting the electronic expansion valve	10 ~ 47 step	35 step	Adjustable
13	Disinfection start up adjusting time	0~23 hour	1hour	Adjustable
14	Selection of pump properties	0/1/2	2	0: no water pump /1: backwater pump /2: solar water pump
15	Backwater temperature setting	15~50°C	35°C	Adjustable
16	Starting temperature difference of backwater pump	1-15°C	2°C	Adjustable
17	Solar pump start temperature difference	5-20°C	5°C	Adjustable
18	Solar pump shut back differential	1-4°C	2°C	Adjustable

19	Low temperature heating replaces heat pumps	0/1	1	0 is not replaced by electric heating. /1 is replaced by electric heating
20	Electric heating starts when defrosting	0/1	0	0 when defrost, electric heating does not start; 1 when defrost, electric heating starts
21	The sterilization cycle	1-30day	14	Adjustable
22	Opening of expansion valve for defrosting	10~47	30	N*10
23	Initial operating time of expansion valve	3~30	21	N*10seconds
24	Low voltage switch detects ring temperature	-10~25	-5	Adjustable
25	Low voltage switch delay detection after press start time	2min-20min	5min	Adjustable
26	Four way valve reversing working ring temperature	-10℃~10℃	-2℃	0
27	After the press starts, the four- way valve on the power time	0-15min	2min	Adjustable
28	Pressure mechanism, electronic expansion valve action options	0-1	0	0doesn'twork/1does
29	Set the temperature to control the heat pump	0-1	0	0:TS1=actualvalue; 1:TS1>manualvalue
30	Compensation temperature	-10-10℃	0℃	Adjustable
31	Ambient temperature sampling frequency	2-120min	15min	Adjustable
32	Electric heating control after heat pump reaches temperature	0-1	1	Adjustable
33	Electrical heating starting	1-10℃	3℃	Adjustable
34	Maximum set temperature of electric heating	65-85℃	75℃	Adjustable
35	Gateway application	0-1	0	Adjustable
36	Minimum operating environment of the compressor	-10℃~20℃	-7℃	Adjustable

37	Minimum opening of the electronic expansion valve	5-30P	8	N*10
38	Target superheat 2	-9 °C ~ 20 °C	6 °C	Adjustable
39	Target superheat 3	-9 °C ~ 20 °C	7 °C	Adjustable

A	Lower water tank temp.	0 ~ 99°C	Actual testing value
B	Upper water tank temp	0 ~ 99°C	Actual testing value
C	Evaporator coil temp.	-15 ~ 99°C	Actual testing value
D	Return gas temp.	-15 ~ 99°C	Actual testing value
E	Ambient temp.	-15 ~ 99°C	Actual testing value
F	Recirculation water temp.\Solar water temp. T6	0~125°C	Actual testing value
G	Electronic expansion valve opening	6~47	N*10
H	Actual set value	10~70°C	Specific calculation see heating mode part
I	Compressor start-up times	0~999	N*20
J	Compressor operating time	0~999	N*24
K	Number of electric heating starts	0~999	N*20
L	Electric heating running time	0~999	N*24
N	Defrosting frequency	0~999	N*20

Malfunctioning of the unit and error codes

When an error occurs or the protection mode is set automatically, the circuit board and the wired controller will both display the error message.

Protection/ Malfunction	Error code	LED indicator	Possible reasons	Corrective actions
Standby		Dark		
Normal running		Bright		
Lower tank water temp. sensor failure	P1	☆● (1 flash 1 dark)	1) The sensor open circuit 2) The sensor short circuit	1) Check the sensor connection 2) Replace the sensor
Upper tank water temp. sensor failure	P2	☆☆● (2 flashes 1 dark)	1) The sensor open circuit 2) The sensor short circuit	1) Check the sensor connection 2) Replace the sensor
Evaporator coil temp. sensor failure	P3	☆☆☆● (3 flashes 1 dark)	1) The sensor open circuit 2) The sensor short circuit	1) Check the sensor connection 2) Replace the sensor
Return air temp sensor failure	P4	☆☆☆☆● (4 flashes 1 dark)	1) The sensor open circuit 2) The sensor short circuit	1) Check the sensor connection 2) Replace the sensor
Ambient temp. sensor failure	P5	☆☆☆☆☆● (5 flashes 1 dark)	1) The sensor open circuit 2) The sensor short circuit	1) Check the sensor connection 2) Replace the sensor
Anti-freeze protection	P6	☆☆☆☆☆☆ ☆☆☆☆☆☆ ● (10 flashes 1 dark)	1) Lower water tank temp too low	The unit will be auto anti-freeze

Low pressure protection (LP Switch)	E2	☆☆☆☆☆ ☆☆● (7 flashes 1 dark)	<ol style="list-style-type: none"> 1) Too low air inlet temp 2) The electronic expansion valve assembly blocked 3) Too less refrigerant 4) The switch damaged 5) The fan assembly can not work 	<ol style="list-style-type: none"> 1) Check if the air inlet temp is over the working limited 2) Replace the electronic expansion valve assembly 3) Charge some refrigerant 4) Replace a new switch 5) Check if the fan working when the compressor working. If not, some problems with the fan assembly
Over heat protection (HTP Switch)	E3	☆☆☆☆☆ ☆☆☆● (8 flashes 1 dark)	<ol style="list-style-type: none"> 1) Too high tank water temp 2) The switch damaged 	<ol style="list-style-type: none"> 1) If the tank water temp is over 85C, the switch will open and the unit will stop for protection. After the water comes to normal temp, 2) Replace a new switch
Water flow error E5	E5	☆☆☆☆☆ ☆☆☆☆●(9 flashes 1 dark)		<ol style="list-style-type: none"> 1) Please check if water flow switch fails or not. 2) Please check if connection is loose. 3) If solar don't be connected, please shortly connect the switch
Defrost	Defrosting indicate	☆☆☆☆☆ ☆☆☆.....(all long flashes)		
Communication failure	E8	Bright	<ol style="list-style-type: none"> 1) The communication line is not plugged into the socket. 	<ol style="list-style-type: none"> 1) Check if the socket of the communication line is plugged in.

MAINTENANCE

Maintenance activities

In order to ensure an optimum operation of the unit, a number of checks and inspections on the unit and the field wiring have to be carried out at regular intervals, preferably yearly.

- Check the water supply and air vent frequently, to avoid lack of water or air in the water loop.
- Clean the water filter to keep a good water quality. Lack of water and dirty water can damage the unit.
- Keep the unit in a place where it is dry and clean, and which has good ventilation. Clean the heat exchanger every one to two months.
- Check each part of the unit and the pressure of the system. Replace the defect part if there is any, and recharge the refrigerant if it is required.
- Check the power supply and the electrical system, make sure the electrical components are good, and the wiring is well. If there is a damaged part or a strange smell, please replace it in time.
- If the heat pump is not used for a long time, please drain out all the water from the unit and seal the unit to keep it good. Please drain the water from the lowest point of the boiler to avoid freezing in winter. Water recharge and full inspection on the heat pump is required before it is restarted.
- Do not turn the power 'OFF' when you use the unit continuously, or the water in the pipe will freeze and split the pipe.
- Keep the unit clean by means of soft damp cloth, no maintenance is required by the operator.
- It is recommended to clean the tank and e-heater regularly to keep an efficient performance.
- It is recommended to set a lower temperature to decrease the heat release, prevent scale and save energy if the outlet water is sufficient.
- Clean the air filter regularly to keep an efficient performance.

TROUBLESHOOTING

This section provides useful information for diagnosing and correcting certain troubles which may occur. Before starting the troubleshooting procedure, carry out a thorough visual inspection of the unit and look for obvious defects such as loose connections or defective wiring.

Before contacting your local dealer, read this chapter carefully, it will save you time and money.



WHEN CARRYING OUT AN INSPECTION ON THE SWITCH BOX OF THE UNIT, ALWAYS MAKE SURE THAT THE MAIN SWITCH OF THE UNIT IS SWITCHED 'OFF'.

The guidelines below might help to solve your problem. If you cannot solve the problem, consult your installer/local dealer.

- No image on the controller (blank display). Check if the main power is still connected.
- One of the error codes appears, consult your local dealer.
- The scheduled timer does work but the programmed actions are executed at the wrong time (e.g. 1 hour too late or too early). Check if the clock and the day of the week are set correctly, adjust if necessary.

ENVIRONMENTAL INFORMATION

This equipment contains fluorinated greenhouse gases covered by the Kyoto Protocol. It should only be serviced or dismantled by professional trained personnel.

This equipment contains R290 refrigerant in the amount as stated in the specification. Do not vent R290 into the atmosphere: R290, is a fluorinated greenhouse gas with a Global Warming Potential (GWP) = 3.

DISPOSAL REQUIREMENTS

Dismantling of the unit, treatment of the refrigerant, of oil and of other parts must be done in accordance with relevant local and national legislation.



Your product is marked with this symbol. This means that electrical and electronic products shall not be mixed with unsorted household waste.

Do not try to dismantle the system yourself: the dismantling of the system, treatment of the refrigerant, of oil and other parts must be done by a qualified installer in accordance with relevant local and national legislation.

Units must be treated at a specialized treatment facility for re-use, recycling and recovery. By ensuring that this product is disposed off correctly, you will help to prevent potential negative consequences for the environment and human health. Please contact the installer or local authority for more information.

WIRING DIAGRAM

Please refer to the wiring diagram on the electric box.

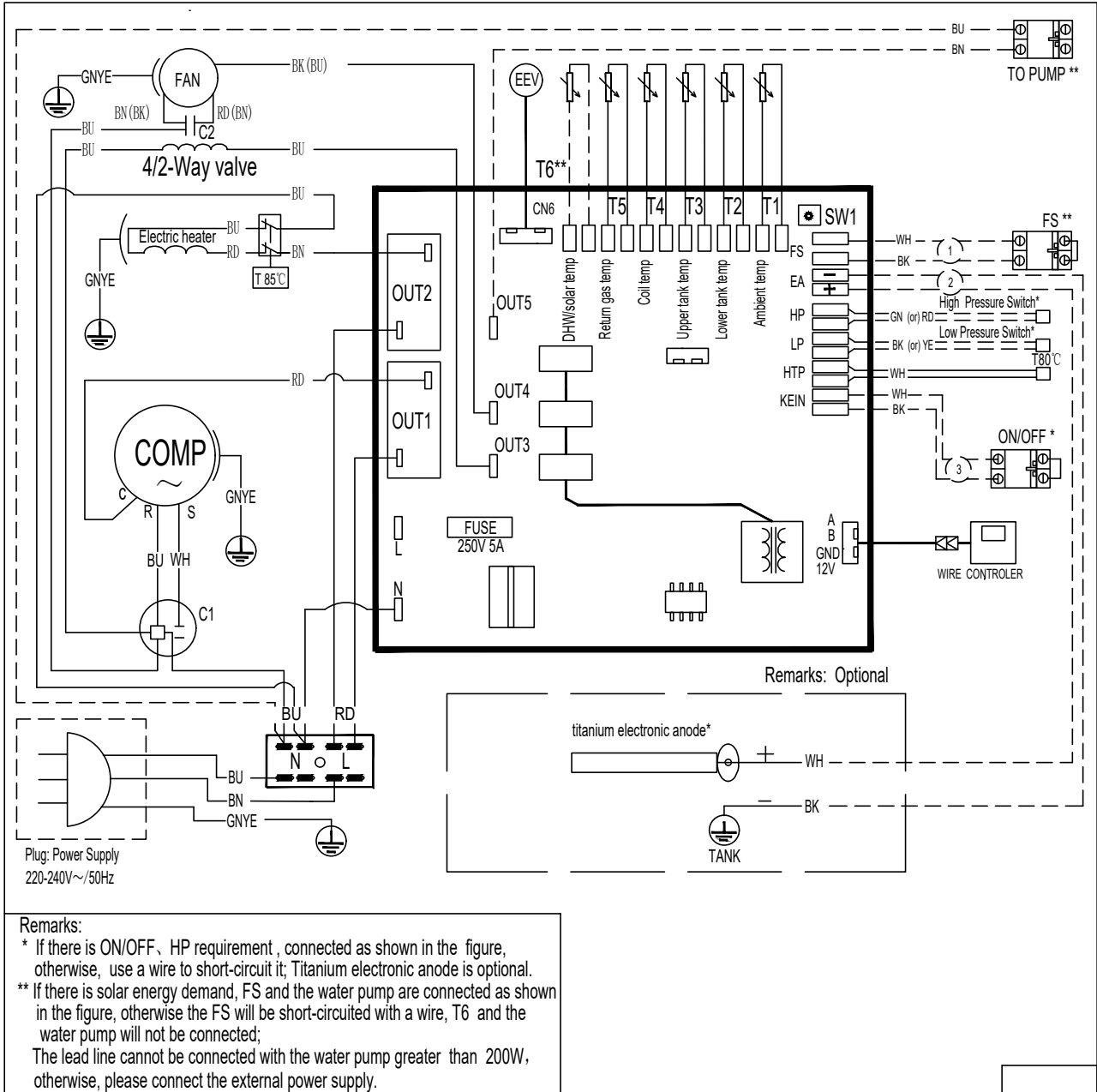

TECHNICAL SPECIFICATION

200L/200LS/300L/300LS

TECHNICAL DATA		200/200 S	300/300 S
Power supply	V/Ph/Hz	220-240/1/50	
Water tank Volume	L	200	300
Heating capacity	kW	1.5* (+1.5**)	1.5* (+1.5**)
Max power input	W	700+1500(e-heater)	700+1500(e-heater)
Max current	A	3.1*+6.5(e-heater)	3.1*+6.5(e-heater)
Max.outlet watertemperature range(without using E-heater)	°C	65	
Max. watertemperature	°C	70	
Min. watertemperature	°C	35	
Ambient working temp.	°C	-5-43	
Max. discharge pressure	bar	32	
Min. suction pressure	bar	0.2	
Refrigeranttype		R290/150g	R290/150g
Compressor	Type	Rotary	
Air flow	m3/h	290	
Duct diameter	mm	177	
Max allowed pressure oftank	bar	10	
Inside body material of tank		Stainless steel \ Duplex steel	
Auxiliary electrical heater	kW	1.5	
Electronic expansion valve		yes	
Hot water outlet	inch	G 3 / 4	
Cold water inlet	inch	G 3 / 4	
Solar energy inlet and outlet	inch	G 3/4 (Solar)	
Condensed water outlet	inch	G 1 / 2	
Heat pump heat exchangermaterial		Microchannel	

TEMPERATURE SENSOR R-T CONVERSION TABLE

R25= 5.0KΩ±1.0% B 25-50 = 3470K±1.0%

°C	Rmin/ KΩ	KΩ	Rmax/ KΩ	°C	Rmin/ KΩ	KΩ	Rmax/ KΩ	°C	Rmin/ KΩ	KΩ	Rmax/ KΩ
-20	36.195	37.303	38.441	21	5.779	5.847	5.914	62	1.343	1.374	1.406
-19	34.402	35.437	36.499	22	5.558	5.62	5.683	63	1.301	1.331	1.362
-18	32.709	33.676	34.668	23	5.346	5.404	5.463	64	1.26	1.29	1.321
-17	31.109	32.012	32.939	24	5.144	5.198	5.252	65	1.221	1.25	1.28
-16	29.597	30.441	31.306	25	4.95	5	5.05	66	1.183	1.212	1.242
-15	28.168	28.957	29.765	26	4.761	4.811	4.861	67	1.147	1.175	1.204
-14	26.816	27.554	28.308	27	4.58	4.63	4.68	68	1.111	1.139	1.168
-13	25.538	26.227	26.932	28	4.408	4.457	4.507	69	1.077	1.105	1.133
-12	24.328	24.972	25.631	29	4.242	4.292	4.341	70	1.045	1.072	1.099
-11	23.183	23.785	24.4	30	4.084	4.133	4.182	71	1.013	1.04	1.067
-10	22.098	22.661	23.236	31	3.933	3.981	4.03	72	0.983	1.009	1.035
-9	21.071	21.598	22.135	32	3.788	3.836	3.885	73	0.953	0.979	1.005
-8	20.098	20.59	21.093	33	3.649	3.697	3.745	74	0.925	0.95	0.975
-7	19.176	19.636	20.106	34	3.516	3.563	3.611	75	0.897	0.922	0.947
-6	18.301	18.732	19.171	35	3.388	3.435	3.483	76	0.871	0.895	0.919
-5	17.472	17.875	18.285	36	3.266	3.313	3.36	77	0.845	0.869	0.893
-4	16.686	17.063	17.446	37	3.149	3.195	3.241	78	0.82	0.843	0.867
-3	15.94	16.292	16.65	38	3.037	3.082	3.128	79	0.796	0.819	0.842
-2	15.231	15.561	15.896	39	2.929	2.974	3.019	80	0.773	0.795	0.818
-1	14.559	14.867	15.18	40	2.826	2.87	2.915	81	0.751	0.773	0.795
0	13.92	14.208	14.501	41	2.726	2.77	2.815	82	0.729	0.751	0.773
1	13.313	13.582	13.856	42	2.631	2.675	2.718	83	0.708	0.729	0.751
2	12.736	12.988	13.244	43	2.54	2.583	2.626	84	0.688	0.709	0.73
3	12.188	12.423	12.662	44	2.452	2.494	2.537	85	0.668	0.689	0.709
4	11.666	11.887	12.11	45	2.368	2.409	2.451	86	0.649	0.669	0.69
5	11.17	11.376	11.585	46	2.287	2.328	2.369	87	0.631	0.651	0.671
6	10.698	10.891	11.086	47	2.209	2.25	2.29	88	0.613	0.632	0.652
7	10.249	10.429	10.611	48	2.135	2.174	2.214	89	0.596	0.615	0.634
8	9.822	9.99	10.16	49	2.063	2.102	2.141	90	0.579	0.598	0.617
9	9.414	9.572	9.73	50	1.994	2.032	2.071	91	0.563	0.581	0.6
10	9.027	9.173	9.321	51	1.927	1.965	2.003	92	0.548	0.566	0.584
11	8.657	8.794	8.932	52	1.863	1.901	1.938	93	0.533	0.55	0.568
12	8.305	8.432	8.561	53	1.802	1.839	1.876	94	0.518	0.535	0.553
13	7.969	8.088	8.208	54	1.743	1.779	1.815	95	0.504	0.521	0.538
14	7.648	7.76	7.872	55	1.686	1.721	1.757	96	0.49	0.507	0.524
15	7.343	7.446	7.551	56	1.631	1.666	1.701	97	0.477	0.493	0.51
16	7.051	7.148	7.245	57	1.579	1.613	1.647	98	0.464	0.48	0.496
17	6.773	6.863	6.953	58	1.528	1.561	1.595	99	0.452	0.467	0.483
18	6.507	6.5911	6.675	59	1.479	1.512	1.545	100	0.439	0.455	0.47
19	6.253	6.331	6.41	60	1.432	1.464	1.497				
20	6.011	6.083	6.156	61	1.386	1.418	1.451				

Note

.....

.....

.....

.....

.....

.....

.....

.....

.....

.....

.....

.....

.....

.....

.....

.....

.....

.....

.....

.....

.....



A2B Accorroni E.G. s.r.l.
Via d'Ancona, 37 - 60027 Osimo (An) - Tel. 071.723991
web site: www.accorroni.it - e-mail: a2b@accorroni.it