

Air / water Heat Pumps
with axial fans

HPE XM 35÷570 MODULAR



ACCORRONI[®]
E. G.

Contents

1. Nomenclature	4
2. Product Schedule	4
3. Technical Features	5
4. Specification	7
5. Dimensions	9
6. Piping Diagrams & Pipe connection drawing	10
7. Wiring Diagrams	12
8. Electric Characteristics	14
9. Capacity tables	15
10. Troubleshooting	19
11. Installation	21
12. Hydronic kit unit	29
13. Testing	31
14. Maintenance	34
15. Control System	37
16. Annex	56

1. Nomenclature

C D A P L 65 – M _____

M: Main unit
A: Auxiliary unit

30 : Unit of 28,5 kw cooling capacity
65 : Unit of 61 kw cooling capacity

L: Low pressure, H: High pressure

Kit pumping group
R410A
Digital Chiller

2. Product Schedule

External appearance











28,5kW module



61kW module

Accessories

CCD	Central control monitor with autorestart+remote ON-OFF	
GA	Kit joints antivibratoires di connexion	
TC	Iron junctions (400 mm) with gasket Kit	
FC	Stemmed flanges with gasket	
DP	Flow switch	
AGD	Shock absorbers	
CC	Condensation control	
CTS	Touch Screen control	

3. Technical Features

■ Adopts digital scroll compressor, the capacity can be realized stepless adjustment

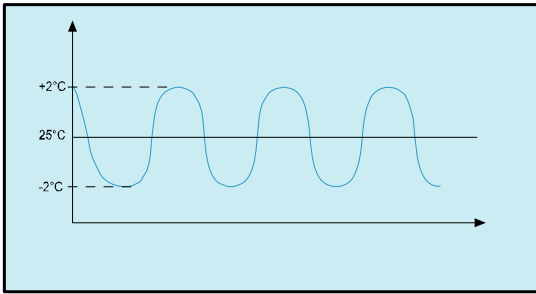

Water temp. fluctuation of module air cooled on-off chiller system

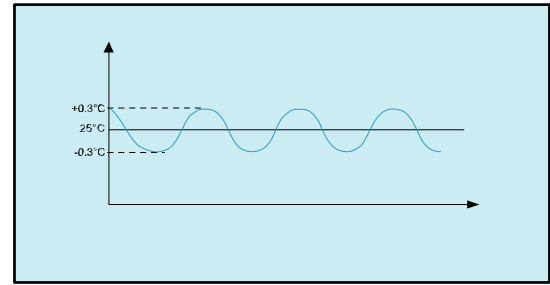

Digital module air cooled chiller oppose of smaller temp. fluctuation of water

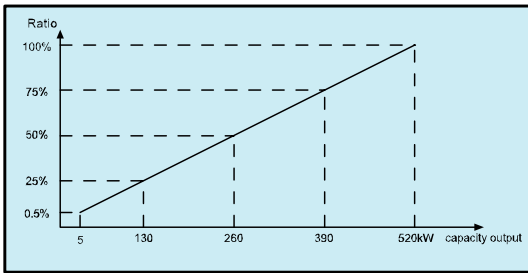

Energy output for digital modular air cooled chiller system

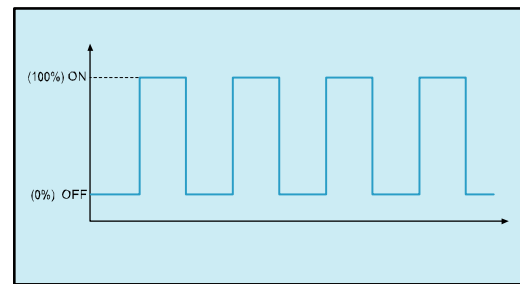

Energy output for traditional modular air cooled chiller system

■ High reliability and efficiency

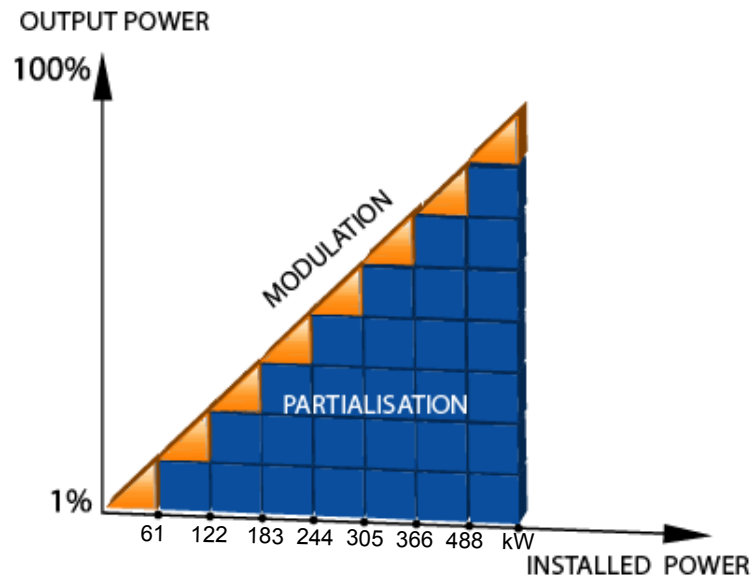

■ Strong micro-computer intelligent control and monitor function.

- Stepless capacity modulation, more efficiency.
- Operation mode control.
- Automatic and uniform adjusting function among multi compressors.
- Anti-frost and anti-cold air functions in heating mode.
- Anti-freezing function of water system in winter.
- Self-protection and Self-diagnosis function.
- Realize auto-restart function with wired controller.
- Built-in remote ON-OFF switch.

■ Easy connection between main unit and slave units.

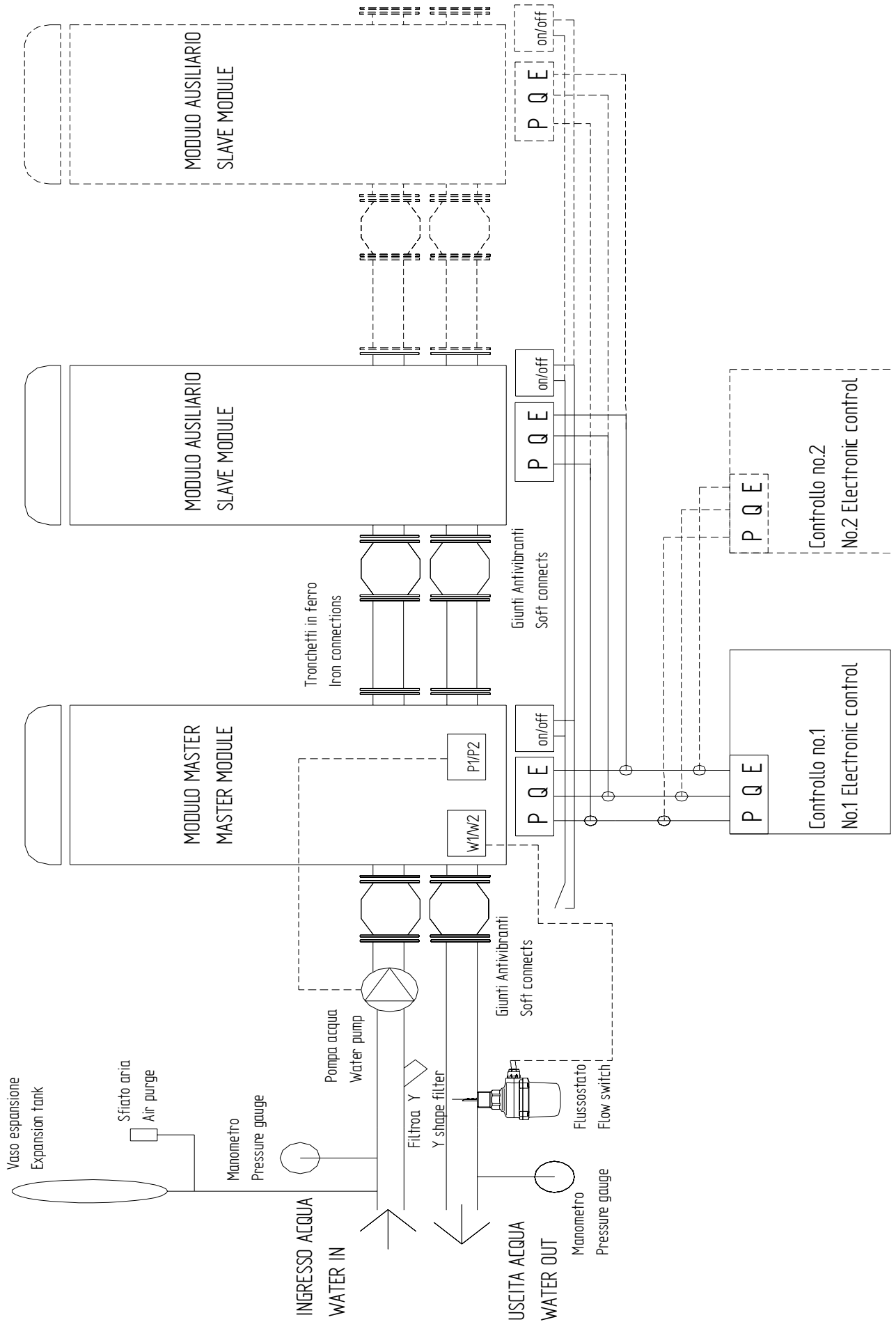

4. Specification

Model		XM							
		35	70	105	145	180	215	250	285
Cooling Capacity	kW	28.5	61	89.5	122	150.5	183	211.5	244
Heating capacity	kW	35	71	106	142	177	213	248	284
Cooling input kW		9.15	18.9	28.1	37.8	46.9	56.7	65.9	75.6
Heating input kW		9.5	19	28.5	38	47.5	57	66.5	76
Power		380V ÷ 415V 3N ~ 50Hz							
Control type		Wire control							
Safety protection device		High/low-pressure switch, anti-frost switch, water-flow switch, over-load protection, and power phases sequence protection.							
30kW master+65kW master+65 kW auxiliary modules		1+0+0	0+1+0	1+0+1	0+1+1	1+0+2	0+1+2	1+0+3	0+1+3
Compressor input kW		8.45	17.5	26	35	43.4	52.5	61	70
Refrigerant		R410A							
Refrigerant kg		7	7*2	7*3	7*4	7*5	7*6	7*7	7*8
Water system	Water flow volume l/s	1.36	2.91	4.28	5.83	7.19	8.74	10.1	11.66
	Water resistance loss kPa	18							
	Waterside heat-exchanger	Welding, stainless steel, plate heat exchanger							
	Max. Pressure MPa	1.0							
	Water inlet/outlet pipeline diameter	133 mm							
Air side heat exchanger	Type	Fin coil							
	Air flow volume *10 ³ m ³ /h	40	42	42	43	45	46	47	48
	Fan motor input kW	0.7*1	0.7*2	0.7*3	0.7*4	0.7*5	0.7*6	0.7*7	0.7*8
Sound pressure	dB(A)	58	60	60	60	60	60	60	60
Dimension (mm)	L mm	1514	2492	2492	2492	2492	2492	2492	2492
	W mm	850	850	3450	4600	5750	6900	8050	9200
	H mm	1820							
Connection wiring	Power wiring mm ² x No	10x5-core							
	Signal wiring mm ² x No	0.75x3-core							
Packaging dimension (mm)	28,5kW master	1620x1034x2041							
	61kW master	2612x1034x2041							
	61kw auxiliary	2612x1034x2041							
Total weight kg		440	700	1140	1400	1840	2100	2540	2800

Model		XM							
		320	355	390	425	460	500	535	570
Cooling Capacity	KW	272,5	305	333.5	366	394.5	427	455.5	488
Heating capacity	KW	319	355	390	426	461	497	532	568
Cooling input kW		84,7	94.5	103.6	113.4	122.5	132.3	141.4	151.2
Heating input kW		85.5	95	104.5	114	123.5	133	142.5	152
Power		380V ÷ 415V 3N ~ 50Hz							
Control type		Wire control							
Safety protection device		High/low-pressure switch, anti-frost switch, water-flow switch, over-load protection, and power phases sequence protection.							
30kW master+65kW master+ 65 kW auxiliary modules		1+0+4	0+1+4	1+0+5	0+1+5	1+0+6	0+1+6	1+0+7	0+1+7
Compressor input kW		78.4	87.5	95.9	105	113.4	122.5	130.9	140
Refrigerant		R410A							
Refrigerant kg		7*9	7*10	7*11	7*12	7*13	7*14	7*15	7*16
Water system	Water flow volume l/s	13.02	14.57	15.93	17.48	18.84	20.40	21.76	23.31
	Water resistance loss kPa	18							
	Waterside heat-exchanger	Welding, stainless steel, plate heat exchanger							
	Max. Pressure MPa	1.0							
	Water inlet/outlet pipeline diameter	133 mm							
Air side heat exchanger	Type	Fin coil							
	Air flow volume *10 ³ m ³ /h	49	50	50	50	51	51	51	52
	Fan motor input kW	0.7*9	0.7*10	0.7*11	0.7*12	0.7*13	0.7*14	0.7*15	0.7*16
Sound pressure	dB(A)	60	60	60	60	60	60	60	60
Dimension (mm)	L mm	2492	2492	2492	2492	2492	2492	2492	2492
	W mm	6650	6650	8100	8100	9550	9550	11000	11000
	H mm	1820							
Connection wiring	Power wiring mm ² x No	10x5-core							
	Signal wiring mm ² x No	0.75x3-core							
Packaging dimension (mm)	28,5 kW master	1620x1034x2041							
	61 kW master	2612x1034x2041							
	61 kW auxiliary	2612x1034x2041							
Total weight kg		3240	3500	3940	4200	4640	4900	5340	5600

5. Dimensions

5.1 28,5kW modular outline:

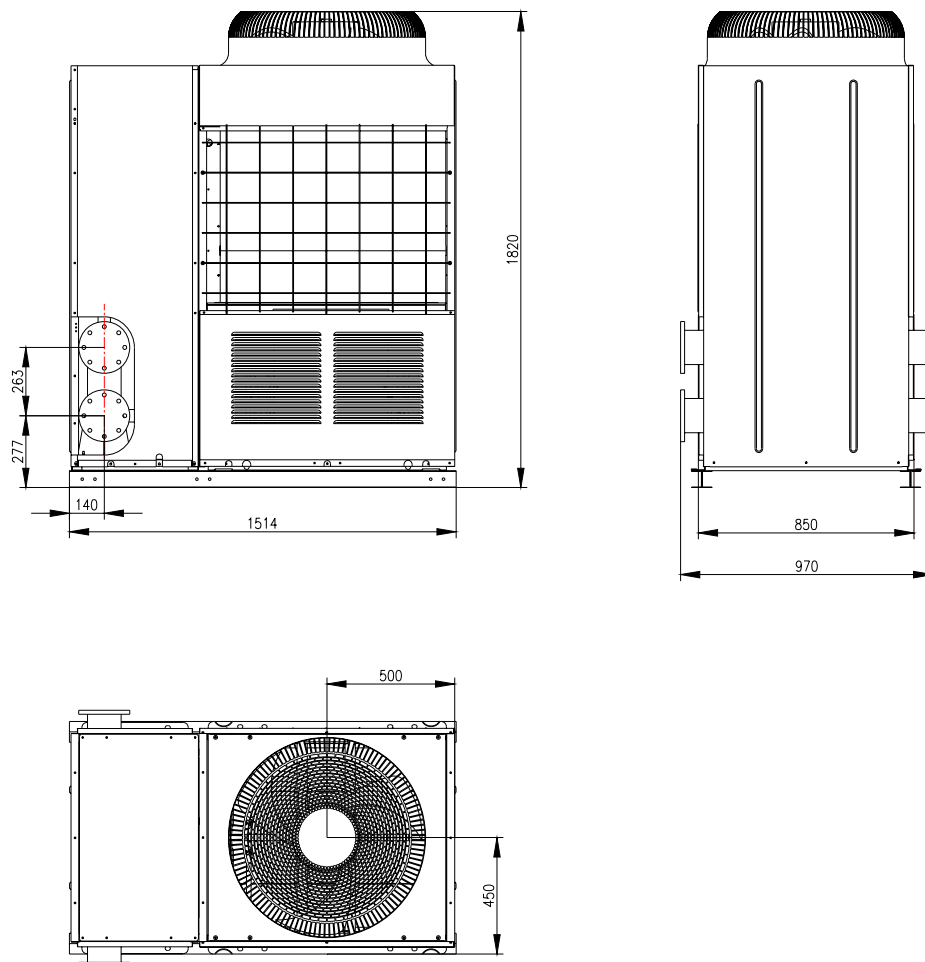

5.2 61kW modular outline:

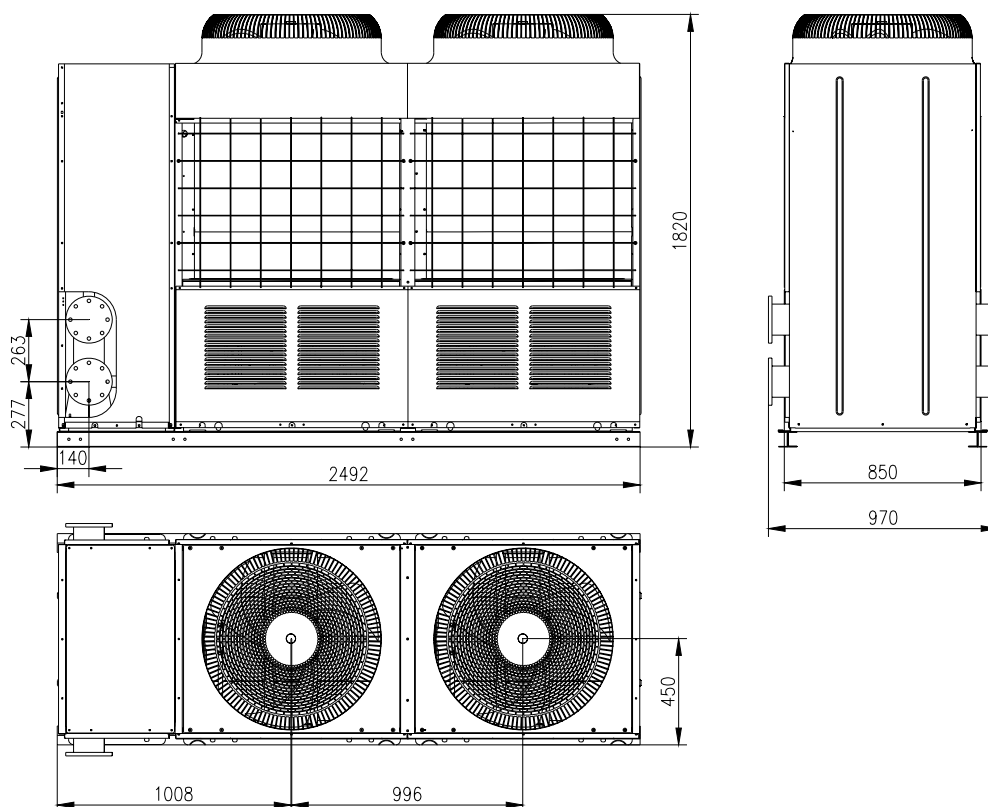

6. Piping Diagrams & Pipe Connection Drawing

6.1 Refrigeration system sketch drawing for 28,5kW module unit

28,5kW module has two separate refrigeration systems (system A and system B), each system consists of one compressor and the two systems share one double-system plate exchanger.

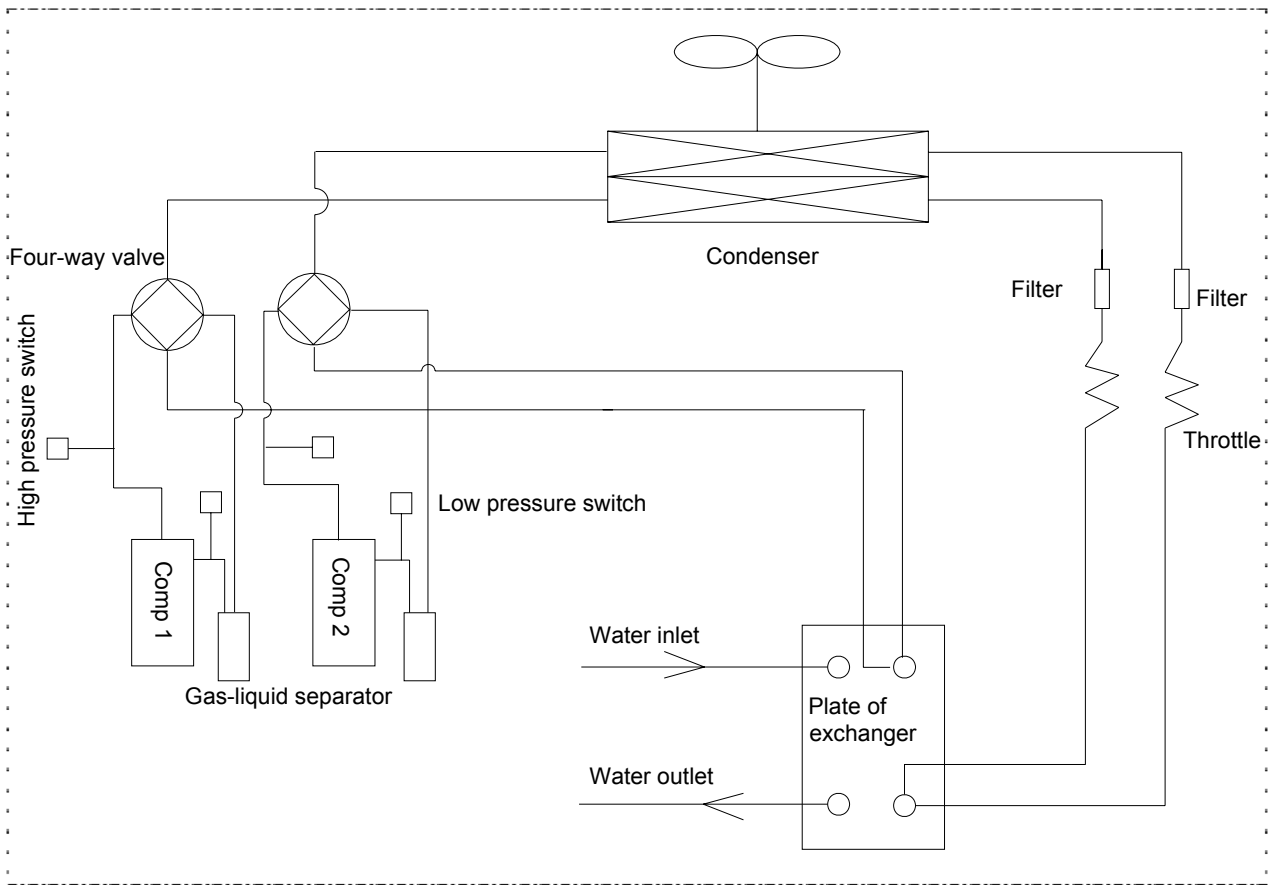

6.2 Refrigeration system sketch drawing for 61kW:

61kW module has two unit modules; the refrigeration system sketch drawing of unit modules is above refrigeration system sketch drawing of 28,5kW.

6.3 Water pipe sketch drawing for 28,5kW module unit system:

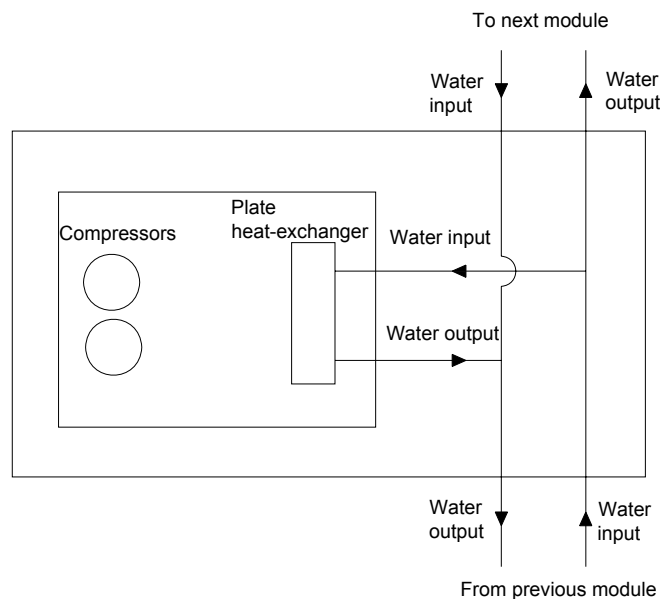

6.4 Water pipe sketch drawing for 61kW module unit system:

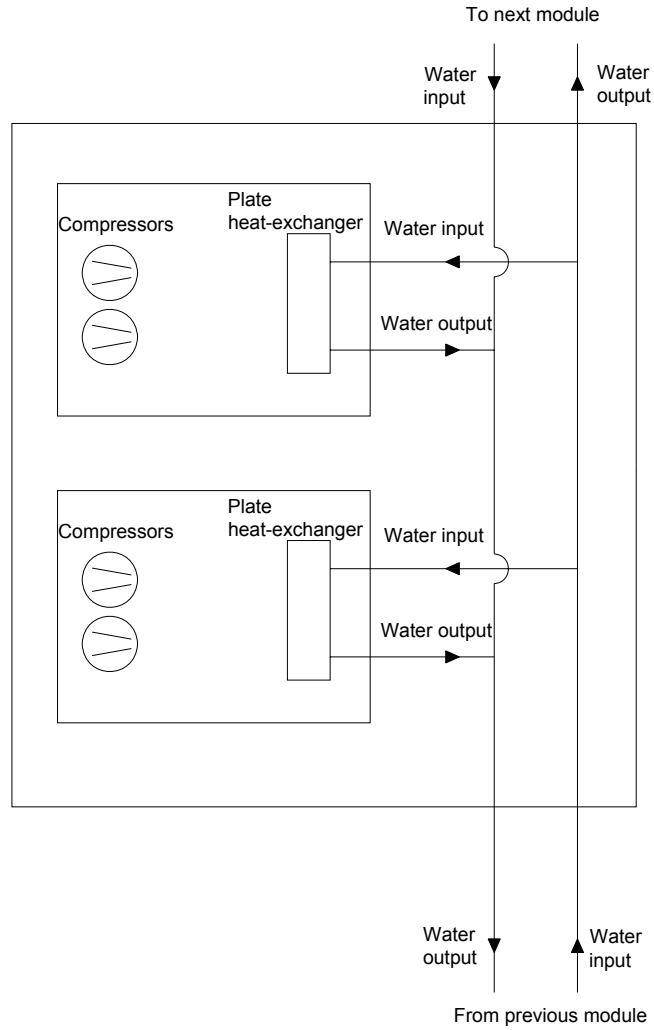

6.5 Sketch drawing of units combination system (28,5kW, 61kW)

Module unit can be combined by single unit, double units or both. By connecting each own inlet & outlet pipeline in series, 1 ÷ 8 modules (2 ÷ 16 units) can be combined and the max. cooling capacity is 488kW, unit system of principle is shown as follows:

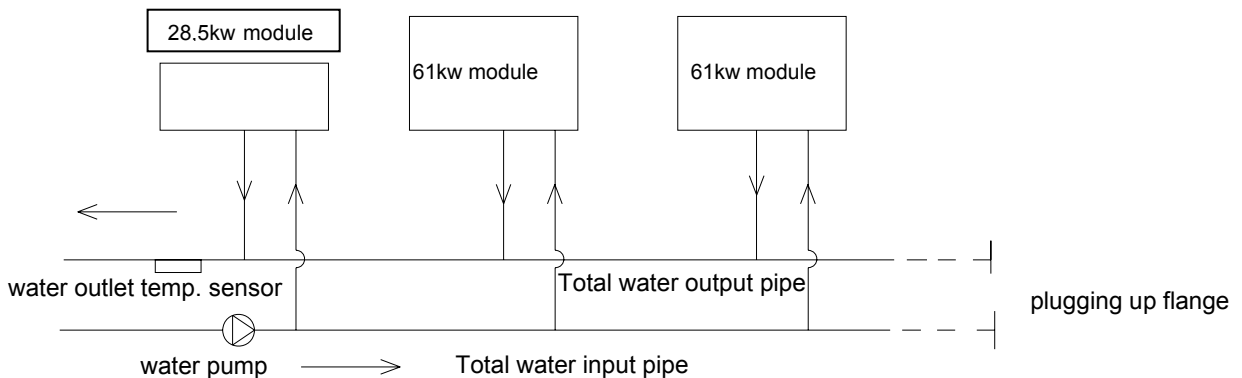

7. Wiring Diagrams

7.1 Outdoor wiring diagram: 28,5 kW & 61 kW

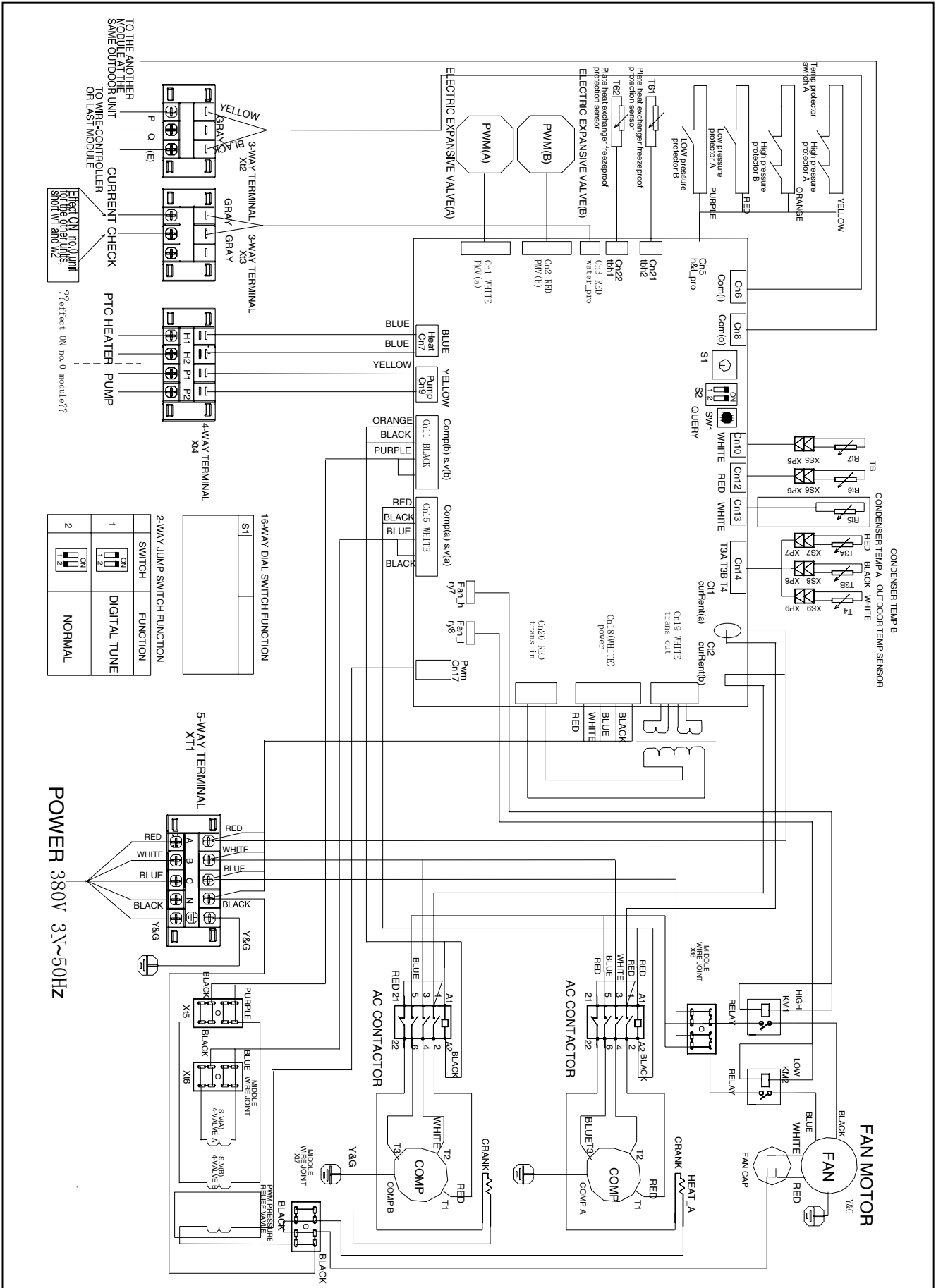

Electric control figure (auxiliary unit)

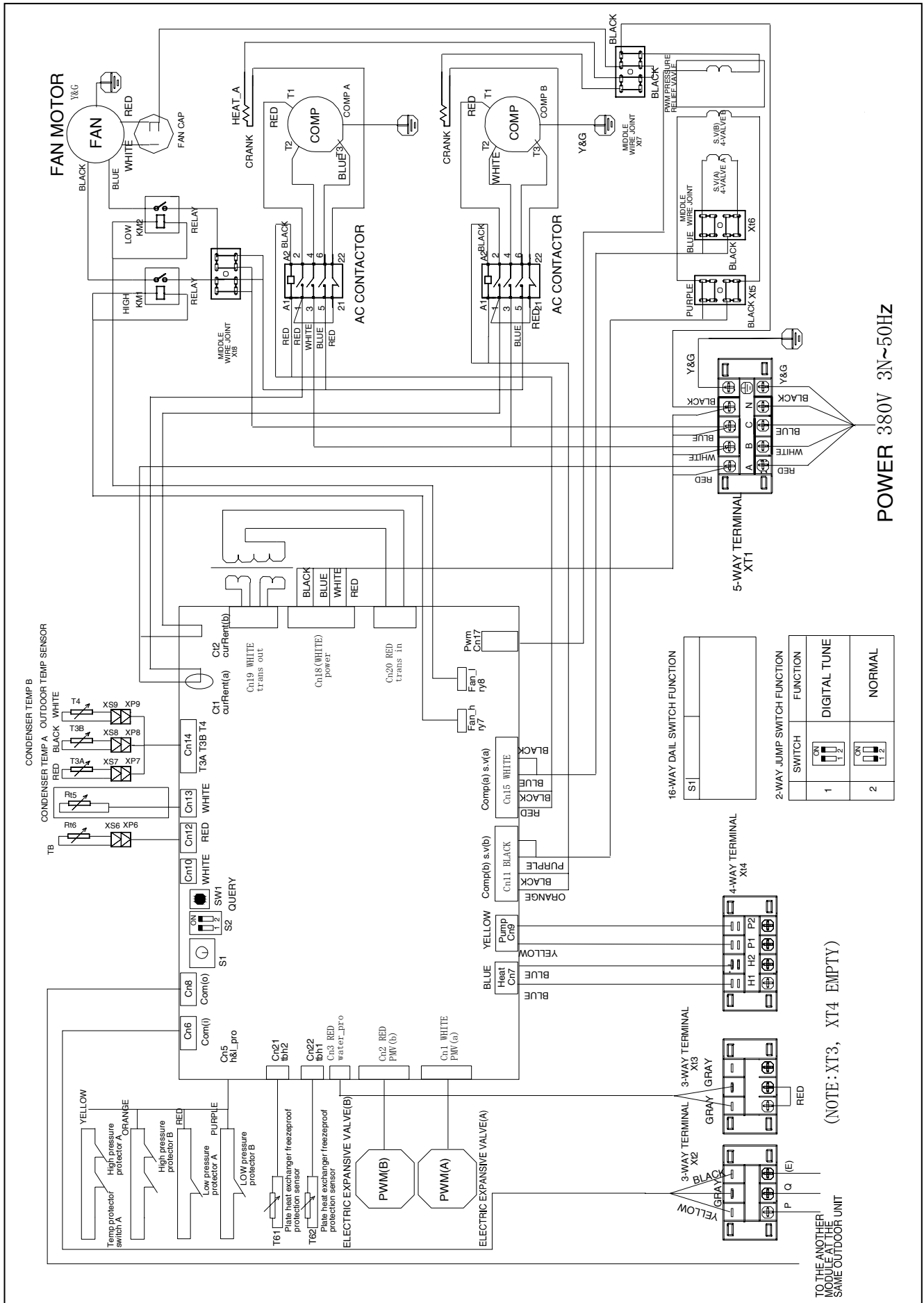

8. Electric Characteristics

Model	Outdoor Unit				Power Supply			Compressor		OFM	
	Hz	Voltage	Min.	Max.	MCA	TOCA	MFA	MSC	RLA	kW	FLA
XM 35-A	50	380	342	418	19.9	24	40	74×2	11.8×2	0.67	3.1
XM 70-A	50	380	342	418	42.9	49	80	74×4	11.8×4	0.67×2	3.1×2
XM 35-M	50	380	342	418	19.9	24	40	74/82.4	11.8/12.7	0.67	3.1
XM 70-M	50	380	342	418	42.9	49	80	(74/82.4) ×2	(11.8/12.7) ×2	0.67×2	3.1×2

Remark:

MCA: Min. Current Amps. (A)

TOCA: Total Over-current Amps. (A)

MFA: Max. Fuse Amps. (A)

MSC: Locked Rotor Amps. (A)

RLA: Rated Load Amps. (A)

OFM: Outdoor Fan Motor.

FLA: Full Load Amps. (A)

KW: Rated Motor Input (kW)

9. Capacity Tables

9.1 Cooling:

28,5 kW

Mod.	TWUE (°C)	PF (kW)					PA (kW)				
		TAMB (°C)					TAMB (°C)				
		20	25	30	35	40	20	25	30	35	40
35	5	29,98	28,87	27,76	26,65	25,54	6,78	7,46	8,13	8,81	9,83
	7	32,20	30,72	29,61	28,50	27,39	7,12	7,46	8,13	9,15	9,83
	9	34,05	32,94	31,83	30,35	29,24	7,12	7,79	8,47	9,15	10,17
	11	36,27	34,79	33,68	32,20	31,09	7,12	7,79	8,81	9,49	10,51
	13	38,12	37,01	35,53	34,42	32,94	7,46	8,13	8,81	9,83	10,51
	15	40,34	39,23	37,75	36,27	35,16	7,46	8,13	9,15	9,83	10,84

61 kW

Mod.	TWUE (°C)	PF (kW)					PA (kW)				
		TAMB (°C)					TAMB (°C)				
		20	25	30	35	40	20	25	30	35	40
70	5	64,17	61,79	59,42	57,04	54,66	14,00	15,40	16,80	18,20	20,30
	7	68,92	65,75	63,38	61,00	58,62	14,70	15,40	16,80	18,90	20,30
	9	72,88	70,51	68,13	64,96	62,58	14,70	16,10	17,50	18,90	21,00
	11	77,64	74,47	72,09	68,92	66,55	14,70	16,10	18,20	19,60	21,70
	13	81,60	79,22	76,05	73,68	70,51	15,40	16,80	18,20	20,30	21,70
	15	86,35	83,97	80,81	77,64	75,26	15,40	16,80	18,90	20,30	22,40

9.2 Heating:

28,5 kW

Mod.	TAMB (°C)	PH (kW)					PA (kW)				
		TWUC (°C)					TWUC (°C)				
		35	40	45	50	55	35	40	45	50	55
35	-10	20,47	20,30				7,26	7,82			
	-7	22,45	22,45	22,45			7,26	7,82	8,38		
	-5	24,43	23,77	23,77			7,26	7,82	8,94		
	-2	27,08	26,42	26,42	26,42		7,26	8,38	8,94	10,06	
	0	29,06	28,40	27,74	27,74	27,74	7,82	8,38	8,94	10,06	11,18
	2	31,04	30,38	29,72	29,72	29,72	7,82	8,38	9,50	10,06	11,18
	5	34,34	33,68	33,02	32,36	32,36	7,82	8,94	9,50	10,62	11,74
	7	36,32	35,66	35,00	34,34	34,34	8,38	8,94	9,50	10,62	11,74
	10	40,28	39,62	38,30	37,64	37,64	8,38	8,94	10,06	11,18	12,29
	15	47,55	46,23	44,91	44,25	43,58	8,94	9,50	10,62	11,74	12,85

65 kW

Mod.	TAMB (°C)	PH kW)					PA (kW)				
		TWUC (°C)					TWUC (°C)				
		35	40	45	50	55	35	40	45	50	55
70	-10	41,53	41,18				14,53	15,65			
	-7	45,55	45,55	45,55			14,53	15,65	16,76		
	-5	49,57	48,23	48,23			14,53	15,65	17,88		
	-2	54,92	53,58	53,58	53,58		14,53	16,76	17,88	20,12	
	0	58,94	57,60	56,26	56,26	56,26	15,65	16,76	17,88	20,12	22,35
	2	62,96	61,62	60,28	60,28	60,28	15,65	16,76	19,00	20,12	22,35
	5	69,66	68,32	66,98	65,64	65,64	15,65	17,88	19,00	21,24	23,47
	7	73,68	72,34	71,00	69,66	69,66	16,76	17,88	19,00	21,24	23,47
	10	81,72	80,38	77,70	76,36	76,36	16,76	17,88	20,12	22,35	24,59
	15	96,45	93,77	91,09	89,75	88,42	17,88	19,00	21,24	23,47	25,71

10. Troubleshooting

10.1 Failure & Protection Codes of the Module

Code	Trouble
E0	Water-flow check trouble(wire controller and control board must be restarted when the trouble is displayed for the third time).
E1	Power phases sequence failure.
E2	Communication failure.
E3	Total outlet water Temperature sensor failure (available for main unit)
E4	Plate heat exchanger outlet water Temperature sensor failure.
E5	Condenser A tube Temperature sensor failure.
E6	Condenser B tube Temperature sensor failure.
E7	Outdoor Temperature sensor failure.
E8	System A compressor discharge gas Temperature sensor failure.
E9	Water-flow check trouble(wire controller and control board can recover automatically when the trouble is displayed for the first and second times.
EA	The number of auxiliary unit checked by main unit decrease(only for wire controller).
EB	Prevent frostbite Temp. sensor of plate heat-exchanger A trouble.
EC	Wire controller can not search the modules on line.
ED	Data communication between wire controller and modules failure(only for wire controller).
EE	Communication between wire controller and computer failure(only for wire controller).
EF	Prevent frostbite Temp. sensor of plate heat-exchanger B trouble.
P0	System A high-pressure protection or discharge gas Temperature protection.
P1	System A low-pressure protection.
P2	System B high-pressure protection or discharge gas Temperature protection.
P3	System B low-pressure protection.
P4	System A current protection.
P5	System B current protection.
P6	System A Condenser high-Temperature protection.
P7	System B Condenser high-Temperature protection.
P8	Digital compressor discharge Temperature protection, when it is above 125°C.
Pb	System anti-freeze protection.
PC	Gas discharge Temp. of digital compressor above 125°C protection(only for wire controller).
PE	Low-temperature protection of plate heat-exchanger.

10.2 Troubles and Solutions

Troubles	Possible reasons	Solutions
High discharge pressure (Cooling)	Air or other gas enter the system	Discharge the gas from refrigerant charging hole, re-vacuuming if necessary
	Fins are dirty or jammed by some obstacles	Splash the fins of condenser
	The condenser wind flow is insufficient or motor fail	Check the condenser motor, repair it if necessary
	High suction pressure	Refer to the "high suction pressure" part.
	Refrigerant over-charged	Discharge the additional refrigerant
	High surrounding Temp	Measure the surrounding Temp
Low discharge pressure (Cooling)	Surrounding Temp. is lower	Measure the surrounding Temp
	Refrigerant leak or insufficient	Leak-hunting or recharging
	Low suction pressure	Refer to the "low suction pressure"
High suction pressure (Cooling)	Refrigerant over-charged	Discharge the additional refrigerant
	High Temp. of the inlet chilled-water	Check the heat insulation of water pipeline
Low suction pressure (Cooling)	Insufficient water flow	Measure the Temp difference between inlet and outlet water, adjust the water flow
	Low Temp. of inlet chilled-water	Check installation
	Refrigerant leak or insufficient	Leak-hunting or recharging
	Scaling in the evaporator	Descaling
High discharge pressure (Heating)	Water flow Insufficient	Measure the Temp difference between inlet and outlet water, adjust the water flow
	Air or other gas enter the system	Discharge the gas from refrigerant charging hole, re-vacuuming if necessary.
	Scaling in the waterside heat- exchanger	Descaling
	High Temp of outlet cooling water	Check the water Temp
	High suction pressure	Refer to "high suction pressure" part
Low discharge pressure (Heating)	Low Temp of cooling water	Check the Temp of cooling water
	Refrigerant leak or insufficient	Leak-hunting or recharging
	Low suction pressure	Refer to "low suction pressure" part
High suction pressure (Heating)	High surrounding Temp	Measure the surrounding Temp
	Refrigerant over-charged	Discharge the additional
Low suction pressure (Heating)	Refrigerant insufficient	Recharging
	Air flow insufficient	Check the running direction of the fan
	Short cycle of air flow	Find the reason which causes short cycle, then eliminate it
	Defrosting insufficient	Four-way valve or heat-sensitive resistance failure, replace them if necessary
Compressor stops by anti-freeze protection (Cooling)	Chilled-water insufficient	Failure of the water pump or water flow switch, maintain or replace them if necessary
	Air enters the water system	Discharge the air
	Failure of the heat-sensitive resistance	If failure confirmed, replace it.
Compressor stops by High-pressure protection	High discharge pressure	Refer to "high discharge pressure"
	High-pressure switch failure	If failure confirmed, maintain or replace it if necessary
Compressor stops by the overload protection	High-pressure both of discharge and suction	Refer to "high discharge pressure" or "low suction pressure" parts.
	High or low voltage, single phase or unbalance of the phases	Check the voltage which should never exceed or below 20V to the rating.
	Short circuit of the motor or terminals	Check the motor and the corresponding resistance of the terminals
	Over-load component failure	Replace it
Compressor stops by the inner Temp sensor or high discharge Temp protection.	High or low voltage	Check the voltage which should never exceed or below 20V to the rating.
	High discharge pressure or low suction pressure	Refer to "high discharge pressure" and "low suction pressure" parts.
	Components failure	Check the inner Temp sensor, when the motor is cool
Compressor stops by the low-pressure protection	Filter blocked before (or after) electric expansion valve	Replace filter
	Low-pressure switch failure	If failure is confirmed, replace it.
	Low suction pressure	Refer to "low suction pressure" part.
Abnormal noise caused by compressor	Compressor liquid pumping caused by the entrance of liquid refrigerant.	Adjust the refrigerant volume, check expansion valve and suction gas degree of superheat.
	Compressor aging	Replace compressor
Other abnormal noise	Panel bolt loosed	Fix all components
	Insufficient strength of the installation foundation.	Refer to "Unit installation" part
Compressor can't start	Current relay open, burning the fuse.	Replace the invalid components
	Open circuit of the control wire	Check the control system connection
	High or low-pressure protection	Refer to the parts above about the failures caused by suction and discharge pressure
	Contacting wire burn out	Replace the invalid components
	Contacting wire burn out	Exchange any two of three phases with each other.
	Water system failure	Check water system
	Failure code displayed by the wire controller.	Confirm the type of failure and take the corresponding measure.
	"OFF" signal input of "ON/OFF" port	Check the "ON/OFF" port signal , it's "ON" normally.
Multiple connection failure of "ON/OFF" port when combination with several modules.	Check the "ON/OFF" port multiple connection wiring in every module, confirm the "red-to-red" and "blue to blue" correspondence	
Air-side heat-exchanger over-frosted	Four-way valve or heat-sensitive resistance failure.	Short cycle of the air flow
	Short cycle of the air flow	Check the system; eliminate the failure causing short cycle.

11. Installation

11.1 Unit Installation

11.1.1 Transportation

- ◆ Be sure that the package will be transported safely, unpack until reach installation site.
- ◆ The leaning angle during the transportation should be smaller than 15 degree to prevent the module from rolling over.
- ◆ When transporting the module with rolling bars, it is recommended to use 6 bars under the module (4 bars with 30kW module), each one should be a bit longer than the width of basement to keep the module's in balance.

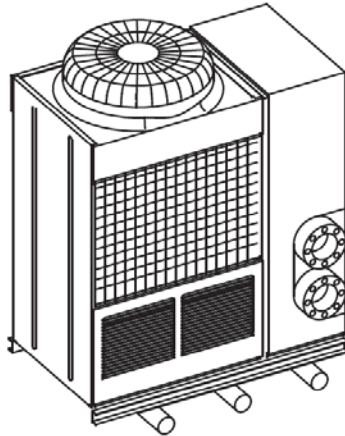

28,5kW module

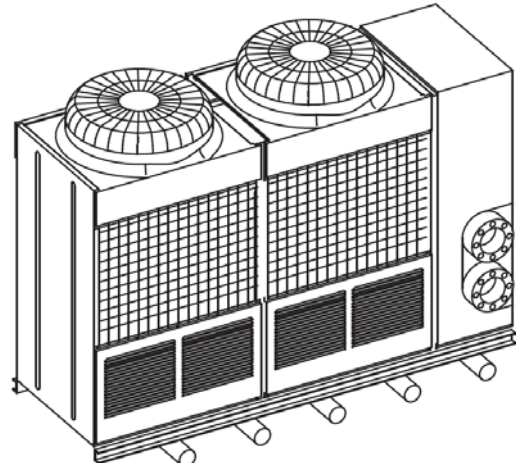

61kW module

- ◆ Sling the module with steel wire, be sure that the wire could bear the weight 3 times heavier than that of the module, and check whether it hooks to module tightly. The hanging angle should be bigger than 60 degrees.

Notice: it is absolutely forbidden to stand under the module while hanging, please use soft board to protect the module surface which contacts the steel wire from scratch and distortion.

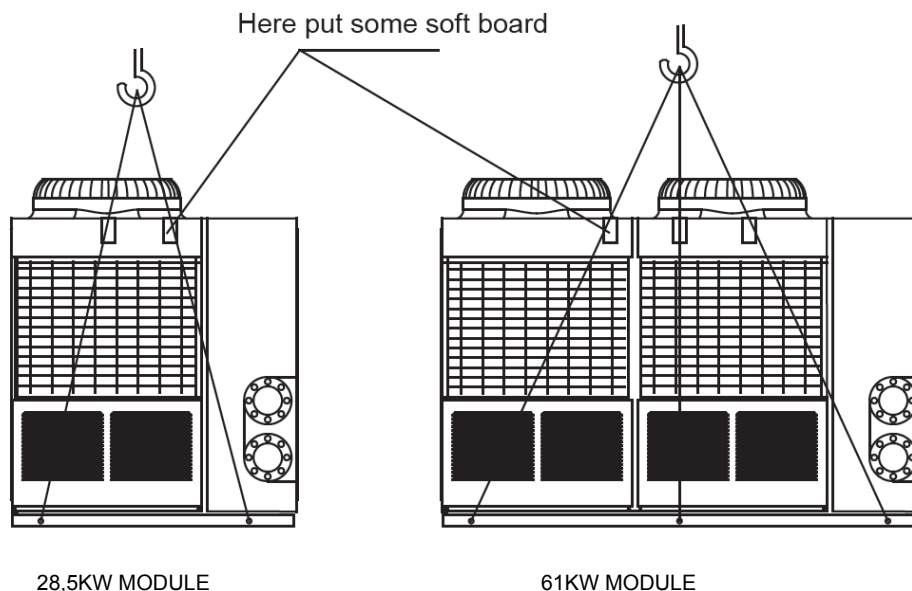

11.1.2 Required installation place

- Clean, bright and well ventilated place such as roof, balcony or courtyard.
- Place without the interference of lampblack, steam and other kind of heat source.
- Place where it is convenient for piping and water drainage with the least influence to surroundings caused by noise,

cool or heat wind.

- Place close to electrical source for wiring.
- Place with solid basement preventing causing resonance and noise.
- Ensure there is sufficient space for the maintenance, the required room is as shown as follows, check whether there are any barriers which would block the airflow. The wall around the module should be not higher than 1m (from the bottom of module). It is recommended to cover the module to prevent rain or snow, but the space between the cover and the top of module should be more than 2m. When parallel installing modules, it is suggested to leave sufficient space among modules for maintenance.

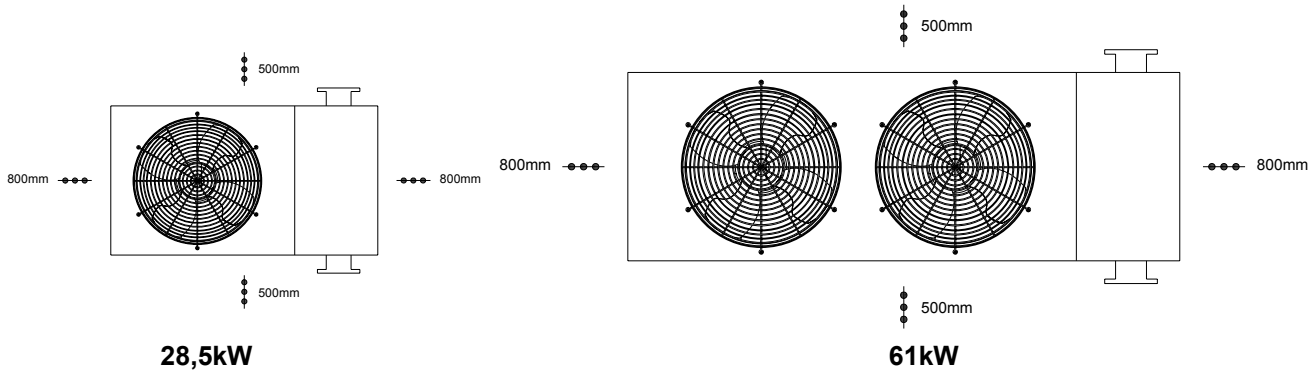

11.1.3 Installation Foundation

- Before installation, structure and prefabrication of the basement should be seriously paid attention to, when installing on the top floor or middle, the floor intensity and noise prevention should be considered, it is referable to communicate with building designer before installation.
- The drainage channel must be made around the basement which ensures the water can be drowning out fluently. In order to avoid the vibration and noise caused by module, a pad for reducing vibration must be set between the module and the basement, moreover, the module should be installed on the plane, and a shockproof basement can be adopted if it is necessary.
- It is recommended to take some measures to strengthen fixing to prevent the movement caused by long-term running, earthquake or typhoon.
- The installation basement for main module (just for reference) is shown as follows; the auxiliary module is the same as the main one. 60mm distance should be left between modules. The weight that the concrete can support should be 1.5 to 2 times more than the weight of modules when the modules are installed on the ground.

11.1.4 Operation Limits

a. The range of voltage:

Power supply: 380V 3ph 50Hz, the permitted max. Voltage: 418V, the permitted min. voltage: 342V.

b. Temperature range for unit operation:

		Cooling		Heating	
		Min	max	Min	max
Inlet water temperature	°C	10	22	40	45
Outlet water temperature	°C	5	17	45	50
Water thermal difference	°C	5	9	5	10
Ambient air temperature	°C	17	48	-10	21
Minimum chilled water outlet temperature with glycol mixture	°C	2			
Max. operating pressure heat exchanger water side	Kpa	100			

* This value can be reduced until -20°C with an optional accessory supplied prefabricated.

11.2 Water System Installation

11.2.1 Every pipeline's joint has outlet and inlet mark. Please notice when connecting pipelines:

- Because the plate heat-exchanger has been used, the space for water passing is narrow, so it is easy to be jammed by particulate, which may cause harmful freezing and damage the system. So it is strongly recommended to install a 20-item mesh net Y-shaped filter close to module-side chilled-water inlet (or cooling water) as much as possible.
- Before connecting the water system to unit, it is necessary to clean the whole water pipeline and replace a new filter net, after ensuring that the water pipeline is clean, the connection can be done.
- The soft connector should be used between the inlet (outlet) water pipeline and the unit to avoid vibration.
- Turn on the water pump before unit starting, the water-flow switch should be installed on the water inlet pipeline before unit and connect pump's wire to main module's W1, W2 terminals.
- Water-discharge switch must be installed on the outlet pipeline and the gas discharge valve on the inlet pipeline, the hand of the discharge switch must be taken away to prevent water shortage caused by wrong hand operation when unit is running.
- The chilled-water pipeline should be covered with adequate heat insulated material to keep the Temp. of the water and prevent dewing.
- In winter, if the unit is shut down, the water in the plate heat-exchanger and pipeline may freeze. To prevent freezing, it is absolutely forbidden to shut down the system (the system has the anti-freeze function) .If there is still be frozen, all the water in the system should be drained away, if it is difficult to drain the water, it is recommended to use some anti-freeze mixture such as glycol or propylene glycol.

Note: It is absolutely forbidden to use salt mixture, because it would corrode the system and cause damage.

- There is no scale problem when using industrial standard water as chilled-water, on other hand, if the water from well or river is used, it may form much scale and sand. So it is necessary to pre-filter the water and intenerate by using relevant equipment before it enters the chilled-water system. If there is sand or mud in the evaporator, it will be blocked and cause freezing .So it is important to test the water's PH value, conductivity, chlorine hydronium, sulfur hydronium etc. before used.

11.2.3 Water tank

KW is the unit for cooling capacity and L is the unit for G water flow in the formula counting the minimum water flow.

Comfortable type air conditioner

$G = \text{cooling capacity} \times 2.6L$

Process cooling application conditioner

$G = \text{cooling capacity} \times 7.4L$

If the total water volume in the system is less than the required minimum volume, the additional water tank is necessary in order to avoid the compressor On and Off frequently. The minimum size of the water tank is calculated as: Size of additional water tank (L)= minimum water volume(L) – Actual water volume (L).

- In certain occasion (especially in manufacture cooling process), for conforming the system water content requirement, it's necessary to mount a tank equipping with a cut-off baffle at the system to avoid water short-circuit, Please see the following schemes:

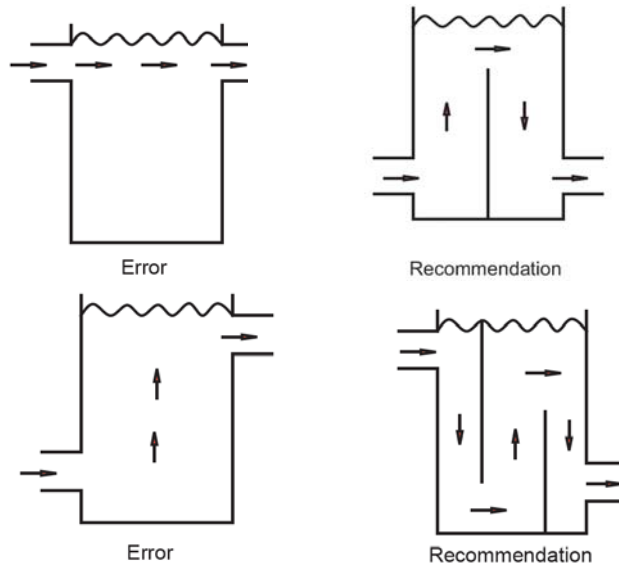

11.2.4 Water Quality

The demanded quality of the water used by system is shown as follows:

The freezing point and the boiling point of the glycol liquor(The consistency of glycol for preventing freezing)

Liquor Consistency%	poidometer	5	10	15	20	25	30	35	40
	volumenometer	4.4	8.9	13.6	18.1	22.9	27.7	32.6	37.5
freezing point °C		-1.4	-3.2	-5.4	-7.8	-10.7	-14.1	-17.9	-22.3
boiling point(100.7kpa) °C		100.6	101.1	101.7	102.2	103.3	104.4	105.0	105.6

The following is the standard of water quality:

PH value:	6.5÷ 8.0	Total rigidity:	<50ppm
Conductivity:	<200µV/cm (25°C)	Sulfur hydronium:	None
Chlorine hydronium:	<50ppm	Ammonia hydronium:	None
Vitriol hydronium:	<50ppm	Xi:	<30ppm
Iron thickness	<0.3ppm	Natrium hydronium:	None
Calcium hydronium:	<50ppm		

Relationship of water quality, furring and causticity

Water quality		Furring	Causticity	Remark
1	PH≤6 acidic water	Hard	Big	Hard CaSO ₄ will be built easily
2	PH≥8 acidic water	Soft	-----	Soft deposit with Fe ³⁺ &Cl ⁻ will be made.
3	Water of Ca ²⁺ , Mg ²⁺	Hard	-----	Hard furring will be built easily.
4	Water of Cl ⁻	Dirt resultant	Very strong	Causticity will be very strong special for iron and copper.
5	Water of SO ₄ ²⁻ , SiO ₂ ²⁻	Hard	Big	Hard CaSO ₄ & CaSO ₂ will be built easily
6	Water of Fe ³⁺	Hard & Dirt resultant	Big	Deposit of Fe(OH) ₃ & Fe ₂ O ₃ will be made.
7	Feculent water	Dirt resultant	Very strong	Causticity will be very strong for copper.
8	Organic compound of water	Dirt resultant	-----	Furring will be built easily.
9	Water of exhaust gas	-----	Big	Copper pipe will be causticized and perforated
10	Water of plastic dust	Dirt resultant	-----	-----
11	Water of sulfurous acid gas in atmosphere	-----	Very strong	-----
12	Water interfused by natural effects of pollution, for ex. humidity nearby sea or hexapod body of garden belt	Dirt resultant	Big	-----

11.2.5 Instruction of the installation

The flow switch may be positioned in every position far from elbows or narrowing, arrow must be oriented downstream. If pipe is vertical, rest range to balance paddle weight. If the device is toward bottom take care of slags, and apply it in a straight pipe upstream and downstream at least five times the diameter, from filters, valves, etc.

Flow rate (DBSF-1RE/DBSF-2RE)		
Pipe connector (ø)	Min. adjustment (m³/h)	Max. adjustment (m³/h)
	Cut-off	Cut-off
1"	0,2 (0,6)	2,0 (2,1)
1 ¼"	0,25 (0,9)	2,8 (3,0)
1 ½"	0,5 (1,2)	3,7 (4,0)
2"	0,9 (2,3)	5,7 (6,1)
2 ½"	1,2 (3,1)	6,5 (7,0)
3"	2,1 (4,9)	10,7 (11,4)
4"	4,9 (11,3)	27,7 (29,0)
4" Z	3,3 (7,7)	17,3 (18,4)
5"	9,7 (22,4)	53,3 (55,6)
5" Z	5,0 (11,5)	25,2 (26,8)
6"	13,6 (31,5)	81,7 (85,1)
6" Z	6,1 (14,1)	30,6 (32,7)
8"	25,7 (59,6)	165,7 (172,5)
8" Z	21,7 (36,5)	90,8 (94,2)

For the models with suffix "Z" the longer paddle must be used to obtain the values indicated in the flow rate schedule.

11.3 Wiring Installation

All wiring installation should be done by qualified person.

11.3.1 Precautions:

1. The power supply must be stable when the unit is running. Considering all voltage-drop factors, the running voltage needed by the system should be kept within $\pm 10\%$ range of the rating. Too high or too low voltage will have bad effect on the unit.
2. The difference of voltage among phases should be not more than $\pm 2\%$ of the rating, and the max current difference among phases should be less than 3% the rating to prevent compressor from overheating.
3. The frequency of the power should be kept within $\pm 2\%$ of the rating.
4. The lowest starting voltage should be more than 90% of the rating.

5. The compressor may be unable to start if the wire is too longer, so the length of the wire should be limited to ensure the voltage-drop between the two ends of the wire is less than 2% of the rating. If it is unavailable to shorten the wire, thicker wire is available.
6. All wire must conform to concerning national standards and well insulated. The insulation between terminals and modules should be checked by 500v high resistance meter and its insulation resistance should be not less than 10MΩ.
7. For safety, according to the concerning standards, unit should be grounded well to prevent electric shock.
8. The running current, input power and other parameters on the nameplate might be different from the actual situation, which is decided by the actual load and cooling water temp., so it is recommended to select power source, transformer, fuse switch and the size of the wire in the consideration of the worst condition.
9. In order to control the compressors conveniently as well as independently and avoid the damage caused by the short circuit, it is necessary to equip the suitable no-fuse air switch for each inlet wire.
10. For 28,5KW & 61 KW, One module consists of two units, each unit's main power should be wired independently and the detail is shown as follow:

Items Model	Power	The minimal diameter Of wire (mm ²) (metal tube, vinylite)		Manual switch (A)		Creepage protector
		Power wire(<30m)	Grounding	Volume	Fuse	
30 kW module 65 kW module	380V ÷ 415V 3N ~ 50Hz	10	10	50	36	100mA

11. Any part of wiring cannot be exposed when wiring is connected to the terminal.
12. Leak electric switch must be set in power supply system of every module unit.
13. The control signal wiring must use two-cores shielded twisted-pair (KVVP 1mm² or RVVP 1mm²). Don't use many-cores wiring (above 3 cores), otherwise the weak signal would be distributed, especially in the place with inverter equipments.

11.3.2 Wiring Specification

1. Category of common wiring.

Wiring model	Description
RV	Cooper core, PVC insulation, tabulate soft wiring
BVV	Fix, lay, cooper core, PVC insulation, PVC jacket cable
RVV	Cooper core, PVC insulation, PVC jacket, circular soft cable
RVVB	Cooper core, PVC insulation, PVC jacket, tabulate soft cable
RVVP	Cooper core, PVC insulation, PVC jacket, screened soft cable
KVV-C	Cooper core, PVC insulation, PVC jacket, control cable
KVVP	Cooper core, PVC insulation, PVC jacket, screened control cable
VV	Cooper core, PVC insulation, PVC jacket, electric power cable
ZR-VV	Anti-burning, Cooper core, PVC insulation, PVC jacket, electric power cable
YCW	Heavy-duty, rubber-bushed, soft electric power cable

2. Specification of control wiring

Description	Length (m)	Specification
Communication signal wiring Wiring controller signal wiring	≤500m	KVVP-300/300 2×1.0mm ² or RVVP-300/300 2×1.0mm ²
Wiring controller power wiring	≤50m	KVVP-300/500 3×1.5mm ²

Remark: shield twisted-pair should be used for communication effect.

3. Diameter selection of grounding wiring

- 1). Minimum section area of insulative grounding wiring is 1.5mm²;

- 2). Minimum section area of exposed grounding wiring is 4mm^2 ;
 3). Maximum section area of grounding wiring is 50mm^2 ;
 4) Commonly, section area is as follow list:

Phase section area of power supply wiring (S)	Grounding and protection wiring
$S \leq 16$	S
$16 < S \leq 35$	16
$S > 35$	S/2

4. Power wiring

(1) Category selection of power wiring

Occasion	Code	Compression resistance	Description
Common	VV	600V/1000V	Cooper core, PVC insulation, PVC jacket, power cable
Anti-burn	ZR-VV	600V/1000V	Anti-burned, cooper core, PVC insulation, PVC jacket, power cable
Armored	VV22	600V/1000V	Armored, cooper core, PVC insulation, PVC jacket, power cable
Anti-oil & outdoors	YCW	450V/750V	Heavy-duty, rubber-bushed, soft electric power cable

(2) Diameter selection

Modules Total Capacity (kW)	28,5kW & 61kW	
	Wiring (mm^2)	
	$\leq 20\text{m}$	
	Diameter of Phase wiring	Diameter of Zero wiring
30	10	6
60	10	6
90	25	10
120	35	16
150	50	25
180	70	35
210	95	50
240	95	50
270	120	50
300	150	70
330	150	70
360	185	95
390	240	120
420	240	120
450	300 or 120×2	150
480	300 or 150×2	150
510	400 or 150×2	200
540	400 or 150×2	200
560	400 or 150×2	200

Remark:

The diameter selections of these preceding cables refer to allowable carrying capacity when no-armored cables 0.6/1KV PVC with three or four-cores, insulation and PVC jacket lay the continuous charge in air. Since different manufacturer with different models, qualities, laid situation and wiring distance ect., the allowable carrying capacity of the cable will be got different influence. For example, if the wiring length is very long, selecting the bigger model should be considered and the circuit voltage down should be confirmed at the same time. So it is suggest that selecting cable should accord to the professional electrician's guidance and refer to the cable manufacturer's technical manuals. The preceding list is only for reference.

7. Water pump control wire connection: the control wire of A/C contactor should through P1, P2 terminals of main unit as follows.

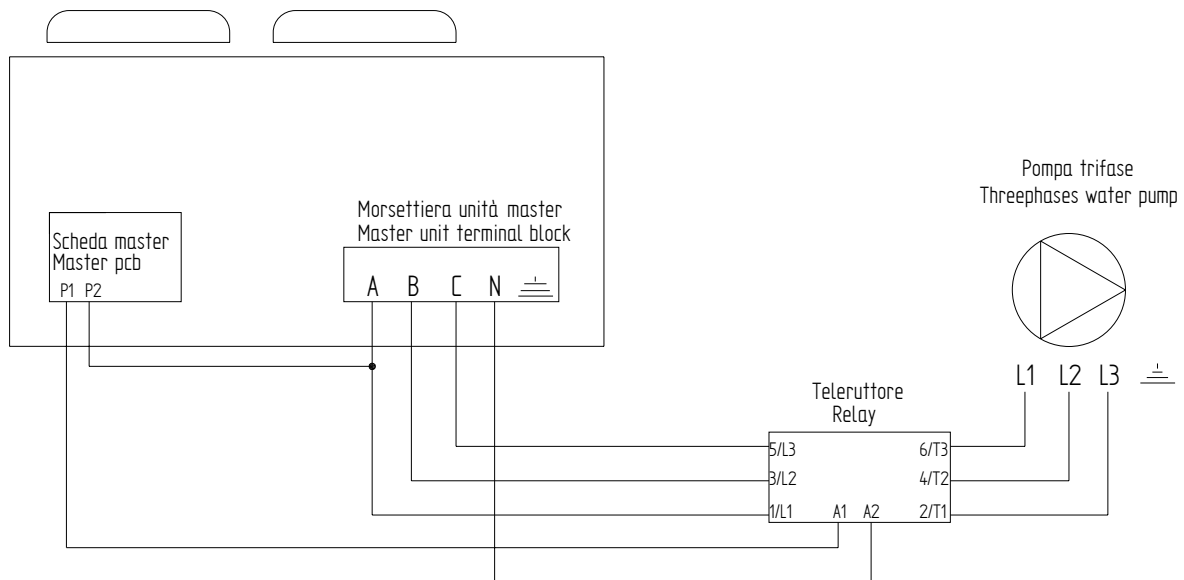

8. Wiring of “ON/OFF” weak electric port: first, corresponding parallel connect the “ON/OFF” port of each module’s electric control box (no more than 16) ,then, connect the “ON/OFF” signal (from the user’s timer) to the “ON/OFF” port of main unit as follows.

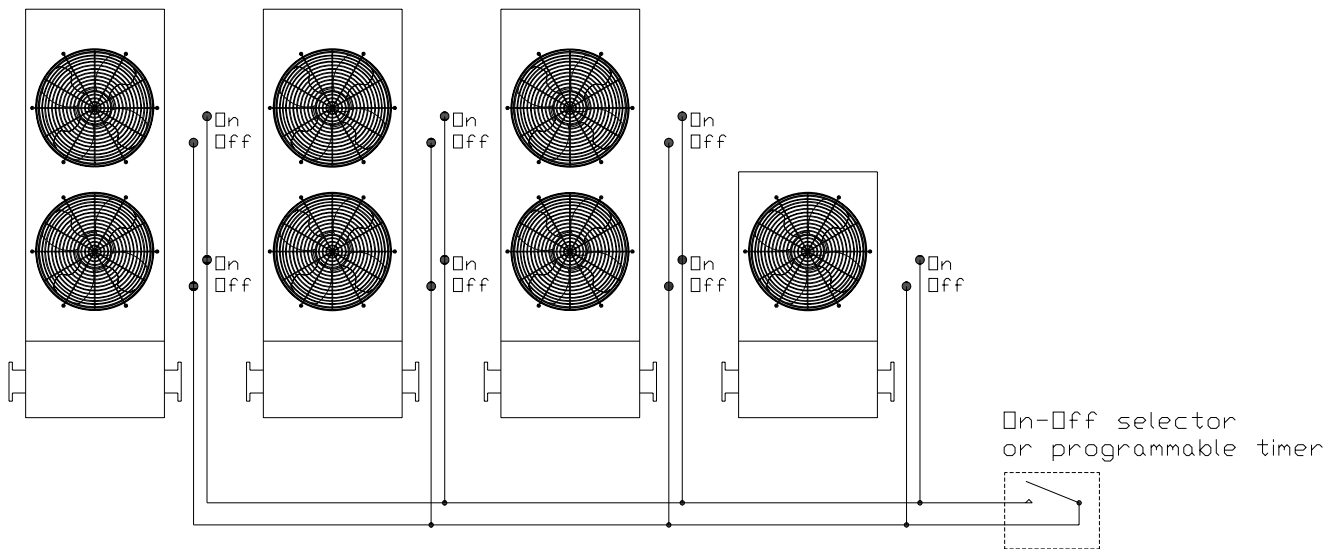

Note:

- 1) Electrify unit 12 hours before starting to pre-heating the compressors, if it is not been done in advance, the compressor may be damaged.
- 2) Regulate the water flow switch and the valve on the inlet pipeline carefully to ensure the water flow can keep the 90% of the rating.
- 3) Check if the components of unit are loose.
- 4) Check if there is any problem of power supply or wiring before starting, especially phases sequence, if it is incorrect, exchange any two of them with each other and ensure all the components are tightly connected.
- 5) Connect the water flow switch correctly to the control cycle.
- 6) Set tightly the Temp. Sensor to the corresponding site of unit.

12. Hydronic kit unit (only for version CDAP-L30, CDAP-H30, CDAP-L65, CDAP-H65).

Hydronic integrated kit enclose:

- low head static pressure pump (versions CDAP-L30 and CDAP-L65)
- high head static pressure pump (versions CDAP-H30 and CDAP-H65)
- auto air vent valve
- auto safety valve opened over 3 bars
- expansion vessel.

Unit model	Pump quantity	Pump type	Static head pressure out from the unit [kPa]	Pump water flow [mc/h]	Expansion vessel volume [L]
XM35IDRO	1	120/07	150	5,22	8
XM70IDRO	2	120/07	150	10,44	8

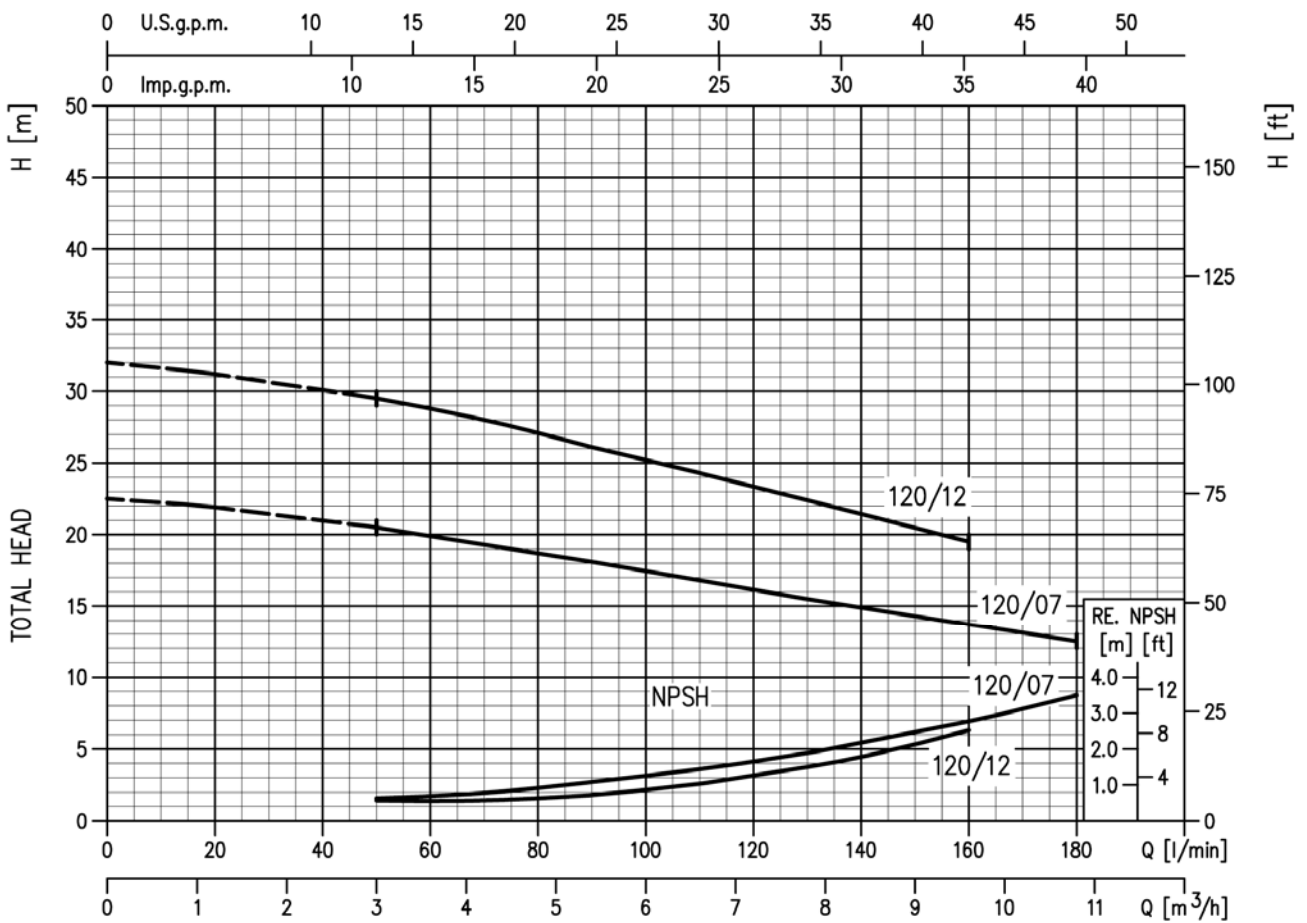

Pump head pressure

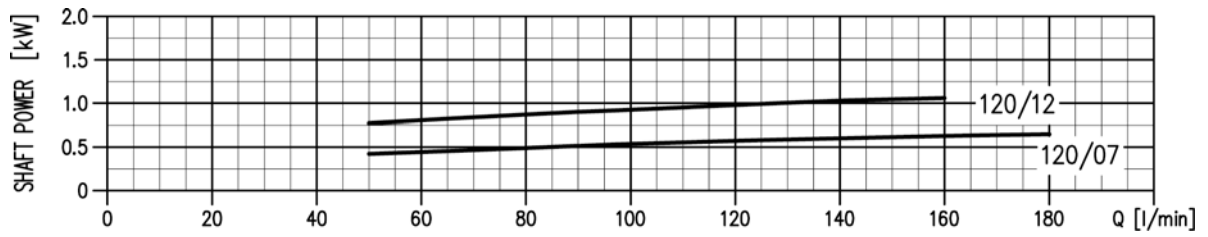

Pump shaft power

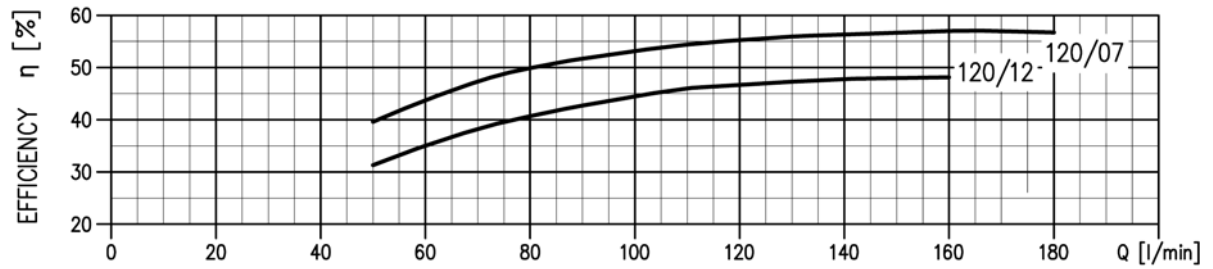

Pump efficiency

XM 35 IDRO

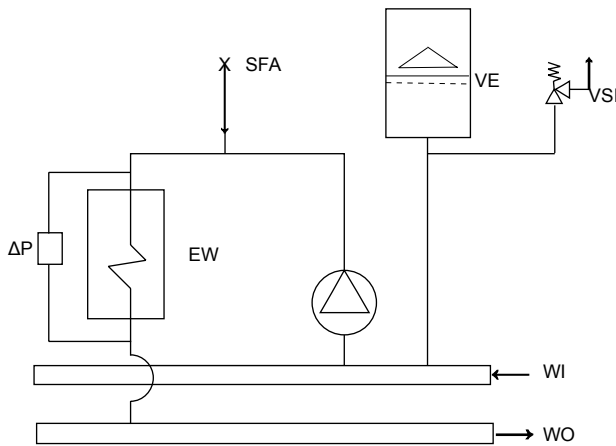

DESCRIPTION	
VE	Expansion vessel
SFA	Purge air
WI	Water inlet
WO	Water outlet
MPS	Single circulating pump
VSI	Safety valve (3 bar)
EW	Evaporator
ΔP	Differential pressure manometers

XM 70 IDRO

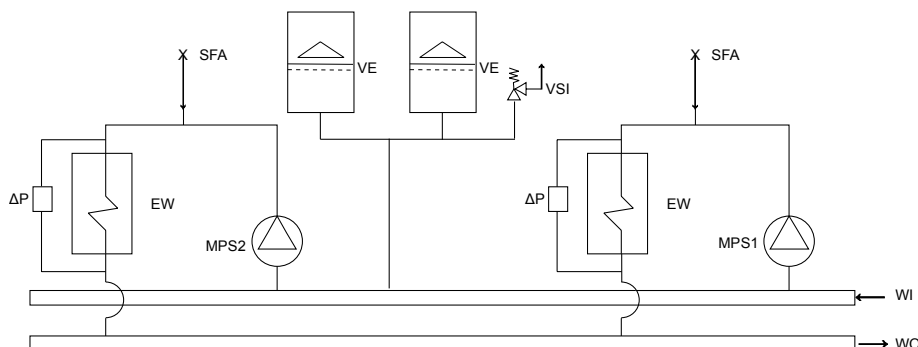

DESCRIPTION	
VE	Expansion vessel
SFA	Purge air
WI	Water inlet
WO	Water outlet
MPS1 MPS2	Single circulating pump
VSI	Safety valve (3bar)
EW1 EW2	Evaporator
ΔP	Differential pressure manometers

13. Testing

1. Preparation

After cleaning the water system pipeline for several times, ensure the water is clean, then pump and drain again, and start the pump to ensure the flow and the pressure of inlet and outlet pipeline is qualified.

Notice: the water pump is under the control of the main unit, so when the water system is running, it can make the control circuit of water pump AC contactor electrify by temporarily wiring, thus to make the water pump running.

Warning: it is absolutely forbidden to start the pump by the control of main unit before the water system has been adjusted well.

1) Please set the address switch on the module unit's PCB according to the rule below.

Warning: address switch setting must be done without any electric supply and when the unit is electrified, setting is absolutely forbidden.

Unit address setting	Corresponding table between address code and unit address																																		
<ul style="list-style-type: none"> 0 presents NO. 0 main unit , 1~F in turn presents NO 1~15 auxiliary units.(respectively) One module consists of two units, so there are two addresses for each module. Address of each unit should not be repeated; otherwise modules would be unable to start due to protection. So it must set the switch to different address code. <div data-bbox="327 1041 603 1317" style="text-align: center;"> </div>	<table border="1" style="width: 100%; border-collapse: collapse;"> <thead> <tr> <th style="width: 15%;">Address code</th> <th>Unit address</th> </tr> </thead> <tbody> <tr><td>0</td><td>NO. 0 main unit</td></tr> <tr><td>1</td><td>NO. 1 auxiliary unit</td></tr> <tr><td>2</td><td>NO. 2 auxiliary unit</td></tr> <tr><td>3</td><td>NO. 3 auxiliary unit</td></tr> <tr><td>4</td><td>NO. 4 auxiliary unit</td></tr> <tr><td>5</td><td>NO. 5 auxiliary unit</td></tr> <tr><td>6</td><td>NO. 6 auxiliary unit</td></tr> <tr><td>7</td><td>NO. 7 auxiliary unit</td></tr> <tr><td>8</td><td>NO. 8 auxiliary unit</td></tr> <tr><td>9</td><td>NO. 9 auxiliary unit</td></tr> <tr><td>A</td><td>NO. A auxiliary unit</td></tr> <tr><td>B</td><td>NO. B auxiliary unit</td></tr> <tr><td>C</td><td>NO. C auxiliary unit</td></tr> <tr><td>D</td><td>NO. D auxiliary unit</td></tr> <tr><td>E</td><td>NO. E auxiliary unit</td></tr> <tr><td>F</td><td>NO. F auxiliary unit</td></tr> </tbody> </table>	Address code	Unit address	0	NO. 0 main unit	1	NO. 1 auxiliary unit	2	NO. 2 auxiliary unit	3	NO. 3 auxiliary unit	4	NO. 4 auxiliary unit	5	NO. 5 auxiliary unit	6	NO. 6 auxiliary unit	7	NO. 7 auxiliary unit	8	NO. 8 auxiliary unit	9	NO. 9 auxiliary unit	A	NO. A auxiliary unit	B	NO. B auxiliary unit	C	NO. C auxiliary unit	D	NO. D auxiliary unit	E	NO. E auxiliary unit	F	NO. F auxiliary unit
Address code	Unit address																																		
0	NO. 0 main unit																																		
1	NO. 1 auxiliary unit																																		
2	NO. 2 auxiliary unit																																		
3	NO. 3 auxiliary unit																																		
4	NO. 4 auxiliary unit																																		
5	NO. 5 auxiliary unit																																		
6	NO. 6 auxiliary unit																																		
7	NO. 7 auxiliary unit																																		
8	NO. 8 auxiliary unit																																		
9	NO. 9 auxiliary unit																																		
A	NO. A auxiliary unit																																		
B	NO. B auxiliary unit																																		
C	NO. C auxiliary unit																																		
D	NO. D auxiliary unit																																		
E	NO. E auxiliary unit																																		
F	NO. F auxiliary unit																																		

2) Digital scroll modular and Normal scroll modular can be selected according to DIGIT switch.

	<p>“00” presents to select digital compressor (as the main unit.)</p>
	<p>“11” presents to select constant compressor (as the auxiliary unit.)</p>

Notice:

a. The DIGIT switch has been set well in the factory and needn't change.

- b. Please turn on the main power 12 hours before starting to preheat the compressor. If the compressor is not preheated enough, it may be damaged.
- 3) Adjust carefully the water flow switch on water system or close valve at inlet to ensure the water flow volume is 90% of the rating.
 - 4) Check if any component of the unit is loose and the unit has no distortion and rupture.
 - 5) Before starting, please check carefully if the power voltage and wiring are right. Check if the power sequence is correct. If not, it needs to be exchanged. Check if the connecting part is tight and fasten once again.
 - 6) Connect the water flow switch correctly to the control cycle.
 - 7) Put the Temp. Sensor to the right position, and then fasten it well to prevent from falling off.

2. Testing

- 1) Turn on the unit by wire controller. If there is ERROR Code displayed, please first eliminate the malfunction; confirm there is no malfunction before restarting.
- 2) After 30 minutes, when the temp of water is stable, adjust the water flow volume to nominal value to ensure the unit running normally.
- 3) When the unit is working, check the Running Current, Running Pressure, Water Pressure, Water flow Volume, Water Temp. Difference between inlet and outlet water, What's more, adjust the water flow volume according to the actual conditions to ensure the unit running normally. The following real values are reference:

Ambient temp.=27°C, Cooling condition

Item \ System	A system (Digital)	A system (Constant)	A system (Constant)	A system (Constant)
Compressor running current	6A	8A	8A	8°
Condenser temp.	39°C	38°C	38°C	37°C

- 4) Optimizing the setting parameters according to the local weather and concerning operation references.
- 5) After the unit stops, start the unit 10 minutes later to prevent the unit from starting frequently. Check if the control and protection devices are normal according to the following table:

Models		30kW module and 65kW module	
For compressor	High-pressure switch Cut off Close	MPa	Reset automatically, unadjusted 4.4 3.2
	Low-pressure switch Cut off Close	MPa	Reset automatically, unadjusted 0.15 0.3
Temp Sensor inside the digital compressor		°C	Controlled by micro- controller When the Temp. is lower than 125°C, compressor will not work. When the Temp. is higher than 125°C, the capacity output of digital compressor will decrease to 40%. When the Temp. is higher than 140°C, compressor will stop. After the malfunction disappears, compressor will restart 3 minutes later.
Over-current protection		A	18
Heating belt Capacity		W	Each compressor has one 40
Discharge Temp. Protection Cut off Close		°C	130 90
Anti-freeze Protection Switch		<input type="checkbox"/>	Controlled by micro- controller (one every cycle.) 3

Notices:

1. Because the water pump is under the control of main unit, it is forbidden to start the pump by the main unit when cleaning water system pipeline.
2. Before finishing draining water out from pipeline, it is forbidden to start unit.
3. Install the water flow switch correctly; otherwise water shortage accident will happen.
4. During test-running, do not restart the unit by manual in 4 minutes after the unit stops.
5. In the season when the unit needs to be frequently used, don't switch off power after the unit stops. Otherwise, the compressor can't be preheated, which may damage the compressor.
6. After a long time without electrifying, please pre-electrify the unit 12 hours in advance to preheat the compressors.

14. Maintenance

To ensure the unit can reliably run for a long time, debugging and maintenance should be done by the qualified persons. The items below should be noticed especially.

Warning:

1. If it is on fire, switch off the main power at once and eradicate the fire with extinguisher.
2. The unit can't be operated near the flammable gas to prevent fire or explosion.

Caution:

1. Maintain unit regularly according to the reference to keep unit in a good condition.
2. Do not touch the discharge pipeline to avoid any scald.
3. If malfunction causes the unit stop, please refer to the "Troubles and solutions" part of this manual or contact with us to find out the reason. After the malfunction is eliminated, the unit can be restarted again. It is absolutely forbidden to forced restart the unit without solving the problems. If refrigerant or chilled water (cooling water) has leakage, it must shut down all switches. If the unit can't be stopped by the controller, it must switch off the main power to stop the unit.
4. Do not use any iron wire, copper wire instead of the demanded fuse, otherwise it will cause the fire and damage the system.
5. Don't make the protection device short-circuited, otherwise it may cause accident.

Maintenance for main components:

1. During running, please notice the discharge pressure and suction pressure. If there is anything abnormal, please find out the reason and eliminate the malfunction.
2. Don't adjust the control and protection devices at random.
3. Check the wire connection regularly to confirm there is no any loose or bad contact caused by oxidation or other reasons. Please frequently check the work voltage, current and phases balance.
4. Check the reliability of the electric components, and replace the invalid and the unreliable in time.

Descaling:

After a long term running, the surface of the heat-exchanger of water side will form calcium oxide and other mineral. Those kinds of material will decrease the heat transfer efficiency, cause more power consumption and higher discharge pressure (or lower suction pressure). These materials can be cleaned by formyl, citric acid, vinegar acid, etc, but any liquid which contains chlorine acid or fluoride ingredient is forbidden. Because the pipe is made of stainless steel, it is easy to be rotted by such material.

1. Cleaning work of waterside heat exchanger should be operated by the professional, please contact with our local MIDEA service center.
2. After cleaning by chemical liquid detergent, scour the pipeline with clean water and heat the exchanger again. Pre-dispose the water to avoid rotting and forming of the scale again.
3. On the condition of using chemical liquid detergent, please select the intensity, cleaning time and Temperature of the liquid according to the actual situation.
4. After cleaning, the waste liquid should be neutralized, so please contact the professional company to get the further disposal for the waste.
5. Detergent and neutralization liquid are harmful to human beings, so it is necessary to use some protective device, such as special glasses, gloves, shoes, mask, etc.

Turn off the unit in winter

When turning off the units in winter, clean and dry the inner and outer surface of the unit, then cover them to prevent dust. Open the water discharge valve, drain away the water in heat exchanger of water side and water pipe to prevent freeze. It is recommended to inject some anti-freeze material into the water pipe.

First start after the unit stops

The following must be done when restarting the unit after a long-term vacancy:

1. Check and clean unit thoroughly.
2. Clean the water system pipeline.
3. Check water pump, adjust switch and other devices of the water system.
4. Tighten all the wire connections.

Accessory replacement

Only MIDEA accessory can be used and please don't use any different one.

Refrigeration system

Check the discharge and suction pressure to determine whether the unit needs to recharge or not. Take leakage test for the system; if there is leakage or some components needs to be replaced, leakage test is necessary. When recharging refrigerant, two cases must be separated:

1. The refrigerant has leaked out totally

In this case, leakage test must be done by using nitrogen ($15 \sim 20 \text{ kgf/cm}^2$) or refrigerant. If necessary, welding should be done after all gas of the system is discharged out.

- 1) Connect the vacuum pump pipeline to the refrigerant charging hole.
- 2) Vacuum refrigerant pipeline more than 15 minutes and confirm it achieve $-1.0 \times 10^5 \text{ Pa}$ (-76 cmHg).

After having achieved the designated vacuity, add refrigerant to the system from the cylinder, corresponding volume of the refrigerant can be got from the nameplate and parameters table. It should be noticed that charging just be allowed from the liquid pipeline side.

- 3) The volume charged into the system will vary from different surrounding Temperature, if the designated volume can't be achieved, unit can be started for recharging while the water system is running. Wire the low-pressure switch to short circuit if necessary.

Notice: rewiring the connection after charging.

2. Additional refrigerant charge

Connect refrigerant cylinder to the refrigerant charging hole and mount a pressure detector on the gas side pipeline.

- 1) Recycle the chilled-water, then start unit, take low-pressure control switch to short circuit if necessary.
- 2) Charge the refrigerant into the system slowly, and check the discharge and suction pressure.

Warning: it is absolutely forbidden to charge the oxygen, acetylene or other gas which is poisonous or flammable into the system for leak hunting or leakage test, just nitrogen or refrigerant is allowed.

Remove compressor

If it is necessary to remove the compressor, please operate with the sequence below:

- 1) Switch off the power
- 2) Remove the electric wire
- 3) Remove the suction and discharge pipeline
- 4) Loosen the fixing bolts.
- 5) Remove the compressor.

System anti-freeze

If plate heat exchanger is frozen, the exchanger will be damaged; in addition, this kind of damage is out of guarantee, so it should be specially noticed. Users should pay special attention to the three points below:

1. When there is a long-term vacancy with low outdoor Temp Water in waterside heat exchanger should be drained out if the Temp below 0°C.

2. When running

If the chilled-water flow switch and anti-freeze Temp Sensor are invalid, water pipeline will be frozen, so the wire of water flow switch must apply to the “wiring principle figure”

3. When maintaining

It is possible to freeze waterside heat exchanger when recharging and discharging refrigerant. Whenever the pressure of the refrigerant is below 0.4Mpa, freezing would happen. So it is necessary to drained out all of the water or keeps the water flowing.

15. Control System

15.1 PCB Outline and Description

15.1.1 PCB, outlook view (28.5kW & 61kW module)

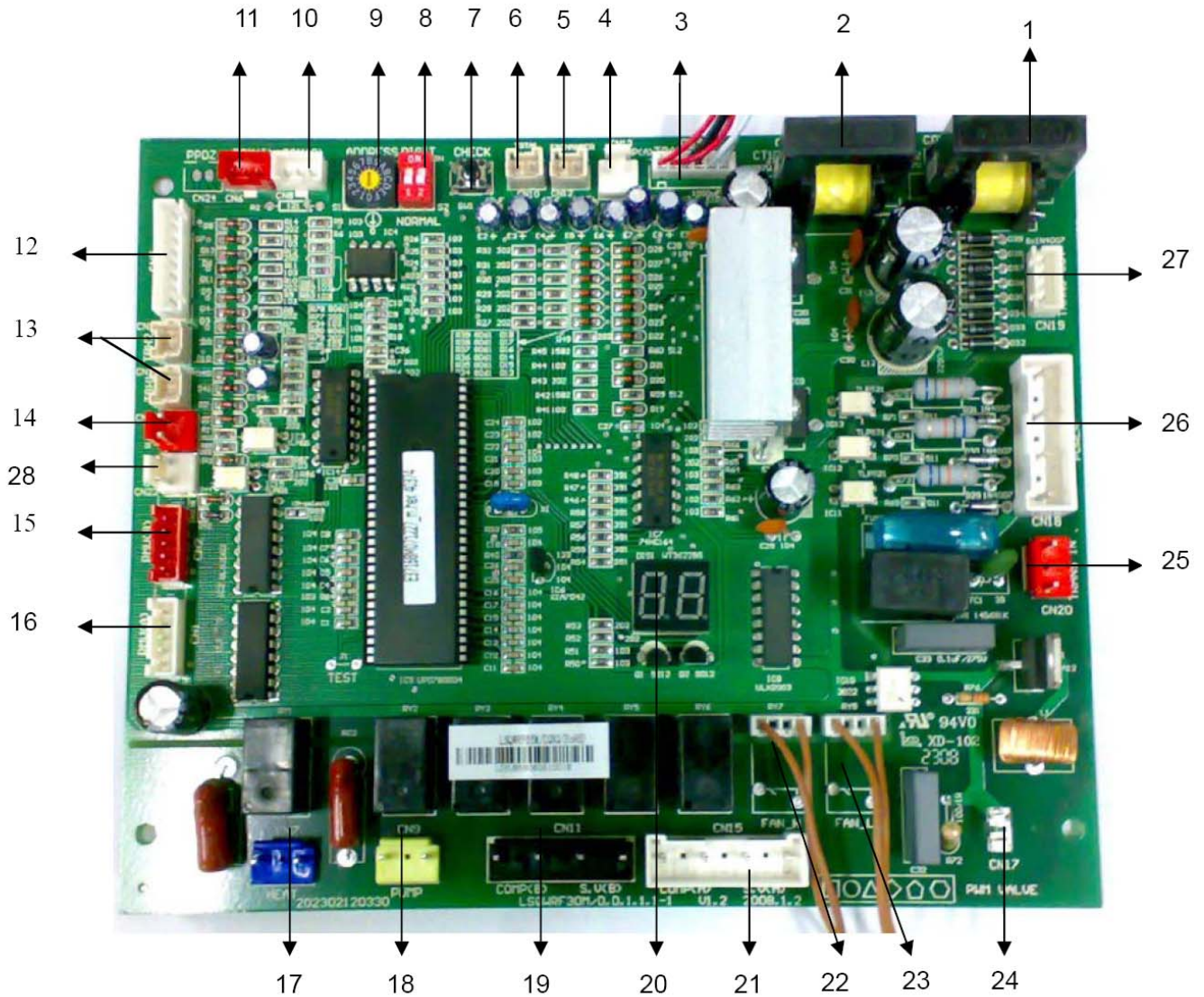

Notice:

1. Failure

When main unit fails, the unit stops as well as the others stop too.

When auxiliary unit fails, this unit stops while the others keep running.

2. Protection

When main unit's protection acts, the unit stops while the others keep running.

When auxiliary unit's protection acts, this unit stops while the others keep running.

14.1.2 Components description of 28.5kW & 61kW module

1. Compressor B current detection (Protection code P5)

2. Compressor A current detection (Protection code P4)

The current will not be detected at the first 5 seconds when starting, after that, if the current is exceeds the pre-set protection standard, (18A for both of digital and constant), compressor will stop, and restart 3 minutes later.

3. T4: Outdoor Temperature sensor (failure code E7).

T_{3B}: Condenser B tube Temperature sensor (failure code E6, protection code P7).

T_{3A}: Condenser A tube Temperature sensor (failure code E5, protection code P6).

- T4

If any one system needs to start the outdoor fan, the fan will be started by the unit electric controller. The fan has two speed levels: high and low which all depends on the T4 Temperature.

- T3B、T3A

When unit electric controller detects the Temperature of T_{3B} or T_{3A} are higher than 65°C, the corresponding system will stop, then restart after the Temperature is lower than 60°C or less. Meanwhile the other system keeps running without any influence.

- T4、T3B、T3A

The alarm will work if the voltage detected by the Temperature sensor is less than 0.05V or more than 4.95V.

- If main unit sensor of fails: all units will stop.

- If auxiliary unit sensor fails: this unit will stop while the others keep running.

4. System A compressor discharge gas Temperature sensor (failure code E8, protection code P8) is only available for main unit.

5. Outlet water Temperature sensor of plate heat exchanger (failure code E4).

Capacity output will adjust according to the outlet water Temperature of the plate heat exchanger both in cooling and heating modes.

(Auxiliary unit) constantly adjusting range: ON and OFF;

(Main unit) digitally adjusting range:

- Cooling mode: OFF, 30%, 40%, 50%, 60%, 70%, 80%, 90% and 100%.

- Heating mode: OFF, 30%, 40%, 50%, 60%, 70%, 80%, 90% and 100%.

6. Total outlet water Temperature sensor (failure code E3), just valid for main unit.

Adjust the capacity output according to the outlet water Temperature of the plate heat exchanger both in cooling and heating modes

Adjusting range: OFF, 40%, 60%, 80%, and 100%.

7. CHECK. It can be achieved by CHECK to observe the running condition of the outdoor systems. The corresponding data will be shown as follows:

CHECK button working

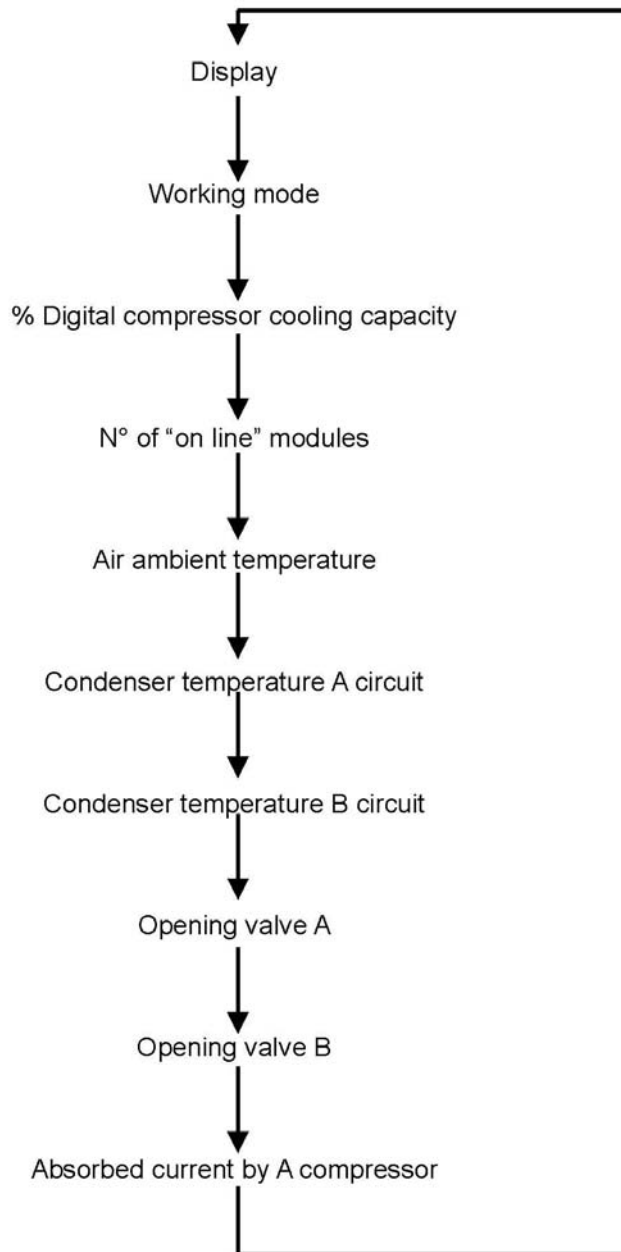

8. DIGIT Digital compressor selecting switch.

<p>DIGIT ON 1 2 0 0</p>	<p>“00” presents selecting digital compressor (as the main unit.)</p>
<p>DIGIT ON 1 2 1 1</p>	<p>“11” presents selecting constant compressor (as the auxiliary unit).</p>

9. ADDRESS

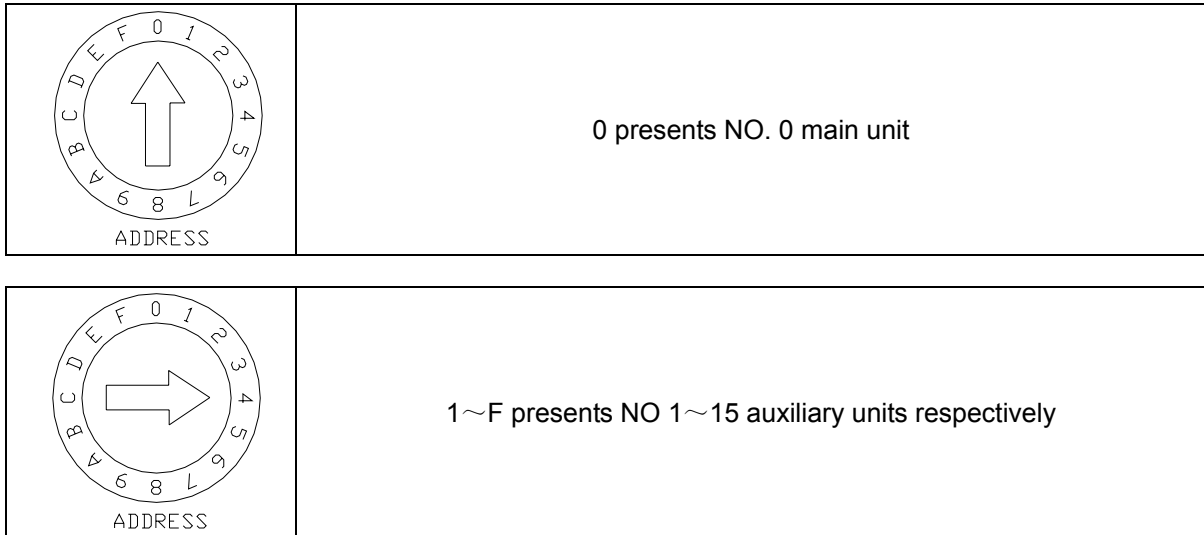

For modular units, each module unit has same electrical control function, while the unit can be set as main unit or auxiliary unit by adjust the address switch of the PCB. The No.0 unit is prescribed as main unit. The digital module unit must be set as main unit and the others are auxiliary units. As long as being set as main unit, the module unit's control system just activates the functions that are the communication with wire controller, the capacity adjustment, water pump control, auxiliary electric heater control, total water temp. detect and water flow switch detect.

10. COM (O) 485 communication port (failure code E2).

11. COM (I) 485 communication port (failure code E2).

P, Q, E points of COM (O) and COM (I) are connected with each other for RS-485 communication.

- If failure occurs between the wire controller and main module, all the units stop.
- If failure occurs between main unit and auxiliary unit, the auxiliary unit with communication failure will stop, and then the number of units online detected by the wire controller will decrease; "EA" will be displayed and the indicator lights will flash.

12. System A high-pressure protection & discharge gas Temperature switch protection (protection code (P0),

System B high-pressure protection & discharge gas Temperature switch protection (protection code (P2),

System A low-pressure protection (protection code P1)

System B low-pressure protection (protection code P3)

- Constant compressor: discharge Temperature switch is connected in series with high-pressure switch.
- Digital compressor: double protection of discharge Temperature Switch and discharge Temperature Sensor, discharge Temperature Switch is connected in series with high-pressure switch, and the discharge Temperature Sensor has its own interface.

Digital compressor has discharge Temperature sensor (which is invalid for the constant), protection is depending on the discharge Temperature (DLT), and it will act for three Temperature areas if the sensor is ok (failure code E8 means sensor absent): safe area without protection when DLT below 125°C; yellow area appears in the condition that the capacity dropping down to 40% of the rating, when DLT is higher than 125°C for 10 minutes. If DLT is lower than 125°C, protection will eliminate, on the other hand, if DLT keeps increasing to 140°C or more, it enter red area when the compressor stop and restart 3 minutes later if the problem has been solved.

13. Anti-frost protection sensor of plate exchanger T6, T62.

14. Water flow check (failure code E0 for main unit) which is just valid for main unit.

- Main unit: main unit controller displays E9 when water flow is abnormal first time and second time and displays E0 when water flow is abnormal third time. (Display resumes after cutting power supply). Wire controller also displays E0 after three times' checking.

- Auxiliary: without water flow checking.

15. System B electric expansion valve.

16. System A electric expansion valve.

EXV can adjust the refrigerant flow according to different running models and capacity requested by surrounding.

17. HEAT auxiliary heater.

Notice: the actual figure of controller of the heater is not 220V power supply but ON/OFF switch!

On heating mode, when the total outlet water temperature is below 45°C, the switch closes and auxiliary heater starts working; on the other hand, when the Temperature is above 50°C, the switch opens to stop heating and heater stops working.

18. WATER PUMP

Notice: the actual figure of controller of the pump is not 220V power supply but ON/OFF switch!

- Water pump will start at once after receiving the opening order and keep running during the whole running term of the system. Pump will close 2 minutes later after all the units having been shut down on cooling or heating mode.

- Pump can be closed directly on the pump mode.

19. System B compressor

- Ground wire
- System B four-way valve
- Ground wire

20. Digital tube

- On waiting mode: display unit address.

- On running mode:

- Main unit display the current capacity of the digital compressor as 40, 60, 80 and 10. (Notice "10" is followed by ".")

- Auxiliary unit display 10. (Notice "10" is followed by ".")

- On failure or protection mode: display failure code or protection code.

21. System A compressor;

- Earth wire
- Four-way valve of system A
- Earth wire

22. High speed of outdoor fan, controlled by T4.

23. Low speed of outdoor fan, controlled by T4.

24. PWM, used for digital compressor capacity adjustment. (It is valid for main unit).

25. Transformer input, 220V/AC.

26. Power input by three-phase four-wire system (E1 for failure code).

A, B, C phases should be supplied together with the 120 degree angle difference among three phases. If it is not qualified, it may cause phases sequence failure or phases absent failure then the corresponding code will be displayed

until the power get right. Notice: phases sequence failure or phases absent failure are just checked at the beginning of electrifying. During the running, they will not be detected.

27. Transformer output

28. "ON/OFF" port

15.3 Controllers

15.3.1 Wired Controller CCD-88B/BE:

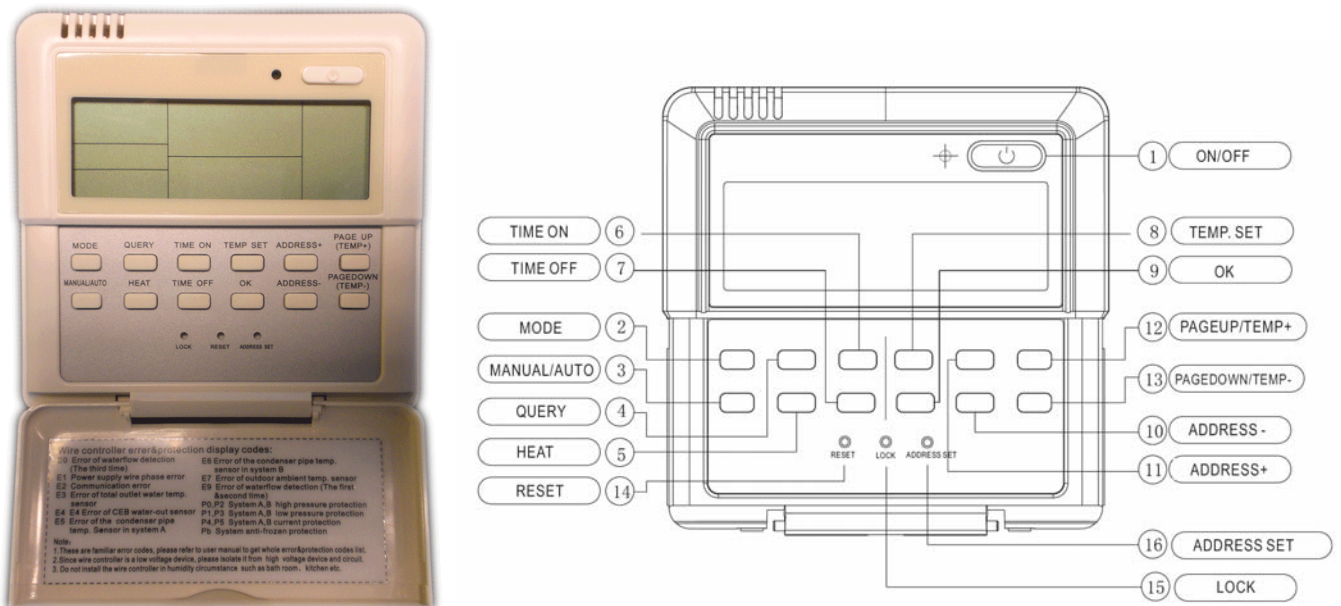

Name of keys on the wired controller and the keypad operation description:

1. ON/OFF button:

In the power off status, press this key and the startup indicator comes on, and the wire controller enters the startup status and keeps the current set information such as temperature value, timing. In the startup status, press this button once, and the startup indicator goes off and transmits the shutdown information.

2. Operation mode button:

In the power off status, press this button to select the operation mode. This function is invalid at power on status.

Modes shifted sequence as follows:

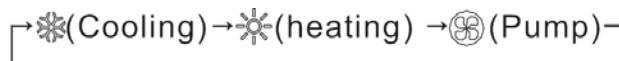

3. MANUAL/AUTO button

Press this button; you could select [MANUAL/AUTO] these 2 modes. When select Manual mode, you could increase or decrease the online units via [PAGEUP/TEMP+] and [PAGEDOWN/TEMP-].

4. QUERY button

Press this button to query the status information of outdoor units 0~15(Outdoor unit 0 by default). After entering the query status, use [ADDRESS+] and [ADDRESS-] keys to query information of the previous or next outdoor unit. After selecting to query a specific outdoor unit, use the [PAGEDOWN/TEMP+] and [PAGEDOWN/TEMP-] keys to query the status information of this outdoor unit. The query sequence is: Outlet water temperature T1->Outdoor pipe temperature T3->Outdoor environment temperature T4->Setting temperature Ts->Current of compressor A and Current of compressor B -> Fault->Protection->Outlet water temperature T1.since there are many fault protection codes for the outdoor unit, the wire controller only displays the two fault protection messages with the highest priority when you check the fault protection information.

5. Heat button

This button has no effect to **CCD/08B/BE**

6 & 7 TIME ON/OFF button

Every time when you press [TIME ON] button, the HOUR and MINUTE of timing startup blink at a frequency of 2Hz. They stop blinking when you adjust the hour and minute; and continue blinking 2 seconds after you stop adjustment. Press [TIME ON] key to select the timing HOUR for adjusting, and the timing hour blinks at frequency of 2Hz. Use the

[PAGEUP/TEMP+] and [PAGEDOWN/TEMP-] keys to adjust the MINUTE. If you keep idle without adjustment operation within 8 seconds after entering the timing setup status, the system will confirm the time setup and exit the timing setup status. Press [TIME OFF] key, as per the above method to set close time.

Long press [TIME ON] button, you could cancel this function. Long press [TIME OFF] button, you could cancel this function.

8. TEMP SET button

Setup the total water outlet temperature in cooling and heating mode. Setup tank or pool temperature in water heating mode.

9. OK button

Once finished upon, press OK key, wire controller will delivery order to main unit.

10. ADDRESS+ button

Press this button at Check mode; when select the next modular, the operation status of the next modular will display; if the current modular is 15# and the next one is 0#.

Press this button for add address at wire address setting mode. If the wire controller address is 15, press this key will display the next address is 0.

11. ADDRESS- button

Press this button at query mode; when select the previous modular, the operation status of the previous modular will display; if the current modular is 0# and the previous one is 15#.

Press this button for minus address at wire address setting mode. If the wire controller address is 0, press this key will display the next address is 15.

12 & 13 PAGEUP/DOWN (TEMP+/-) button

In manual mode, press these keys could add or minus the unit quantity.

In the main page, press these keys could check the operation parameter of the unit.

In temperature setting page, add or minus the temperature setting.

In timing ON/OFF setting, press these keys to adjust the time of startup or closedown.

14. RESET button (Hidden)

Use a 1mm-diameter round stick to press this button, and the current setting will be cancelled and the wire controller enters the reset status.

15. LOCK button (Hidden)

Use a 1mm-diameter round bar to lock the current setting. Press this button again to unlock.

16. ADDRESS SET button (Hidden)

The address of wire controller is set by press this button. The address range 0 ÷ 15, therefore, 16 wire controller could be parallel at most.

When there is only one wire controller, it is no necessary to execute this setting, because the address of wire controller has been set to '0'(main wire controller) in the factory.

Name and function description of LCD screen of wired controller:

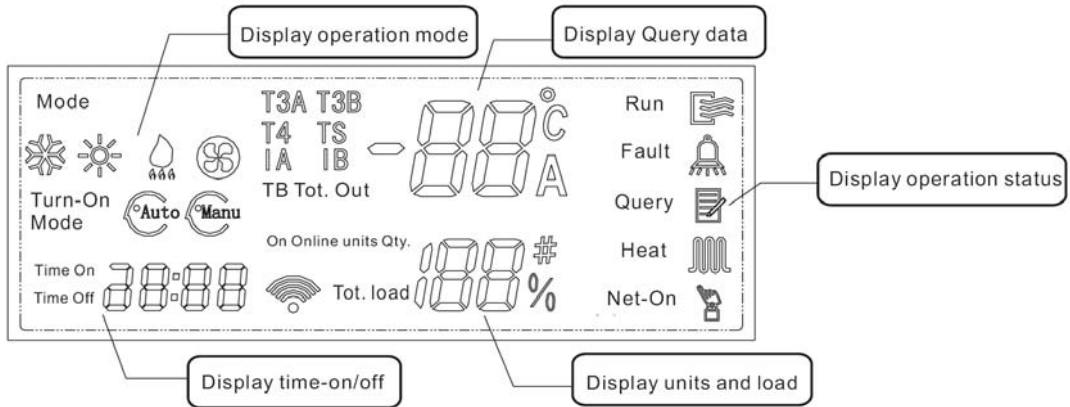

Installation procedure:

1. The wiring procedure and principles are shown in the figure:

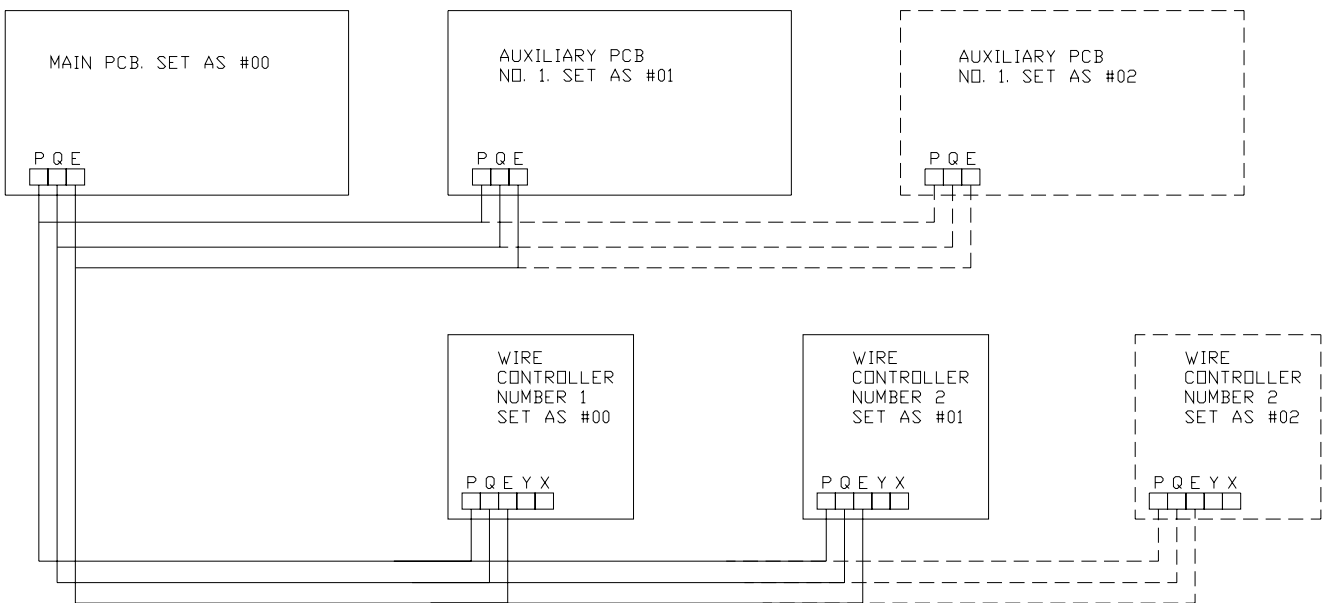

Note: Use PQE position connects with each other when several wire-controllers are parallel.

2. Power connection:

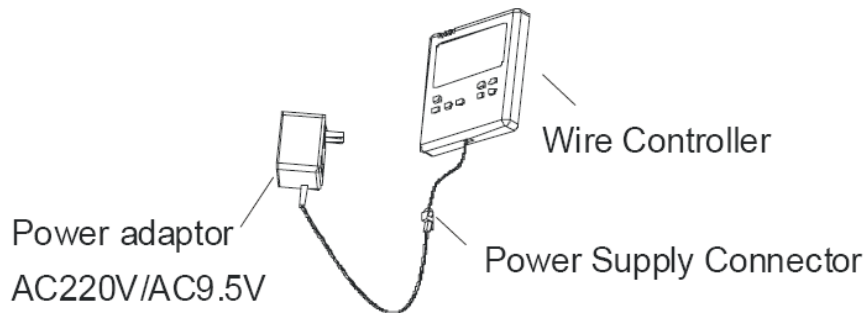

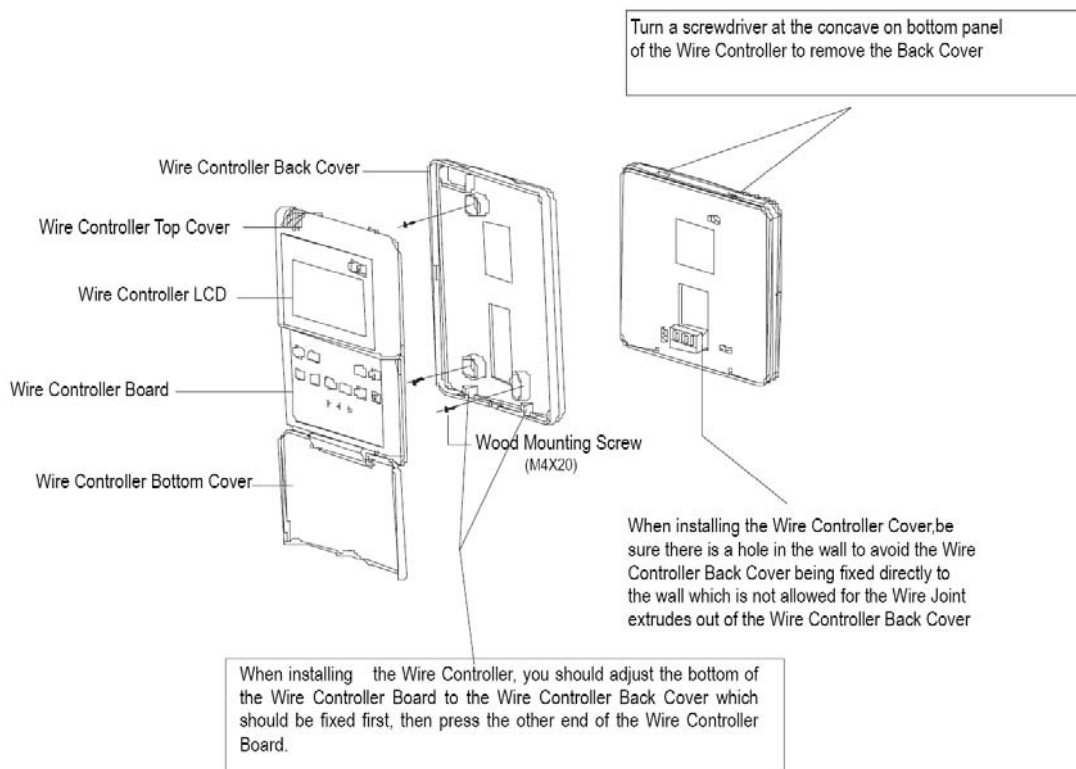

⚠ Note

- Never turn screws too tightly, or else the cover would be dented or the Liquid Crystal breaks.
- Please leave enough long cable for maintenance of the Wire Controller Board.

Operation procedure of wired controller:

1. Press AUTO/MANUAL mode at shutdown status, you could select MANUAL or AUTO turn-on mode as you want. The function is invalid at startup status.

In Manual mode, press [PAGEUP/TEMP+] or [PAGEDOWN/TEMP-] button for select your require online unit quantity.

2. Press [TEMP SET], [PAGEUP/TEMP +], [PAGEDOWN/TEMP -] button, for select your require temperature.

For KJR-08B/BE: Cooling range:5 ÷ 17°C; Heating range:45 ÷ 50°C.

3. Press [ON/OFF] button, running indicator of wire controller is light, unit is start to run, and display running status at wire controller. Press this button once again, unit will stop running.

- Operation procedure of Time ON

1. Press [TIME ON] button adjust your require time by [PAGEUP/TEMP+] or [PAGEDOWN/TEMP-] (MINUTE and HOUR could be shifted by this button). Use the same method to set Time off.

(Note: Time ON/OFF is relative time.)

- Operation procedure of disable the function of Time ON/OFF.

1. Long press [TIME ON] button, you could cancel this function. Long press [TIME OFF] button, you could cancel this function.

- Operation procedure of units information querying

1. Press [QUERY] entering Check status.

2. Press [ADDRESS+] or [ADDRESS-] button, select the unit you are wanted to query.

3. Press [PAGEUP/TEMP+] or [PAGEDOWN/TEMP-] button to query the units information, which includes outdoor ambient temperature T4, pipe temperature T3, setting temperature Ts, CEB out water temp. TB, online quantity and compressor current, etc.

- Operation procedure of system information querying

1. Press [PAGEUP/TEMP+] or [PAGEDOWN/TEMP-] button in the main page, system information could be queried.

- Operation procedure of water temperature setting

1. Press [TEMP SET] button of wire controller when background light is on.

2. Press [PAGEUP/TEMP+] or [PAGEDOWN/TEMP-] button select your require water temperature. Once selected upon, temperature value will blinks a couple of seconds then confirm it.

3. KJR-08B/BE temperature range:

Cooling: 5~17°C

Heating: 45~50°C

- Fault alarm handing

When unit fails or the wire controller detects failure of communication with the outdoor units, the indicator blinks. After all faults of the system and the wire controller are eliminated, the indicator stops blinking. The fault indicator and the operation indicator share the same LCD.

15.3.2 CCM10 LCD Touch Screen (optional)

It can control 8 units, 16 compressors. Control function as Query/Mode setting/Lock/Weekly timer setting/Power failure memory.



Mechanical installation

LCD touch screen normally installed in the casing of unit or the front board of console. Before installation, you should drill a mounting hole at unit casing or the front board of console firstly; and then, the thickness of the front not exceeds than 6mm; thirdly, LCD touch screen cannot be drilled. See following figure for outline dimension of the screen and size of drilled hole.

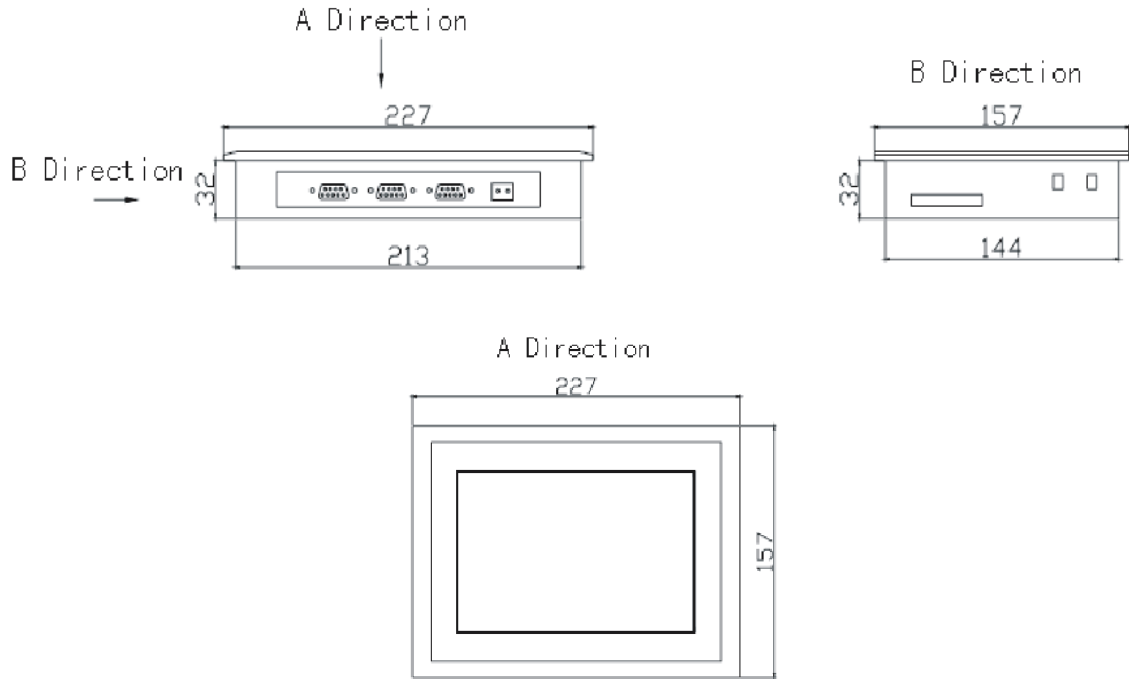

For guarantee the defective-proof level of the front board maintains at IP65, when installing you should install a gasket correctly as following processes:

Mount LCD into mounting hole from forehead of the casing or console. Fix LCD up and ensure it would not fall down. Insert the attached hooks to corresponding flutes of LCD. Flutes sites are arrowed as following figure

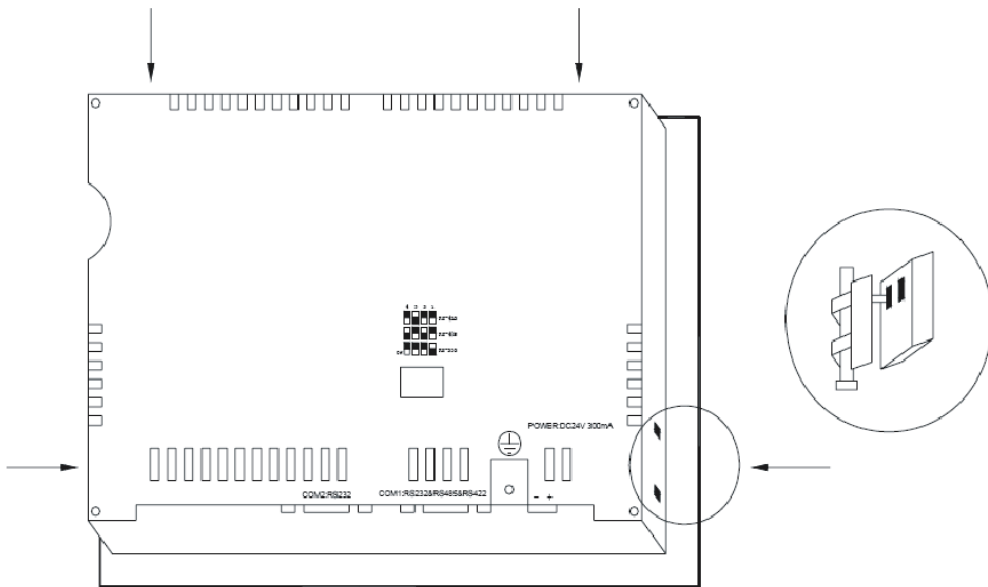

Fix LCD at fore panel from rear side of the panel by screw driver. You must insure that the installing site of gasket is correct; torque is 0.5Nm or less, if not, screen would be damaged.

Electrical installation

LCD electrical interface composed by a power supply interface and three Serial Communications ports. Electrical wiring illustration as follows:

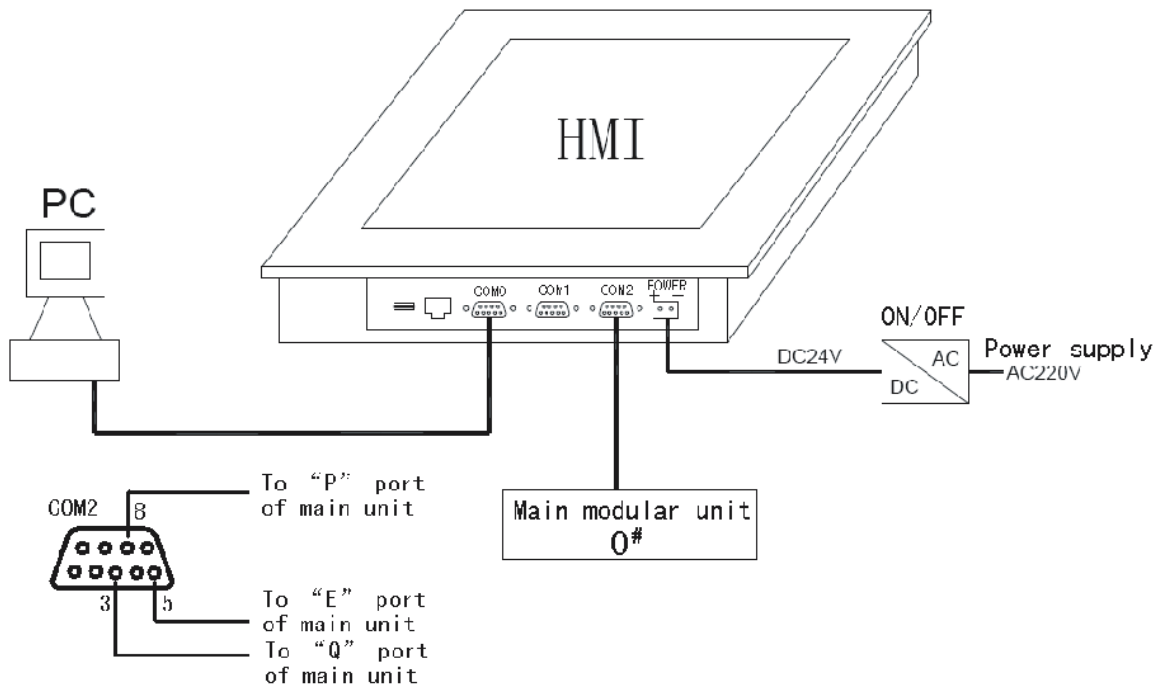

Power supply as DC24V; the 2pin plug seat, positive pole in left and negative one in right. Please be strictly differentiating these two poles.

Three sets of DB9 pin serial ports, which are COM0, COM1, and COM2. COM0, the communication port of RS232, which is the special serial port for uploading or downloading programs between LCD and PC; COM1 and COM2 are ports that integrated by RS485 and RS422, which communication protocol could be selected by the code switch at the rear of LCD. We employ RS485 communication protocol and set unit communicate via the port of COM2, therefore, COM2 switch codes shall be set as below:

Serial protocol	The 1 bit	The 2 bit	The 3 bit	The 4 bit
RS 485	ON	OFF	OFF	OFF

When wiring, please connect the 8 foot of COM2 plug seat to "P" port locating at the communication terminal of main modular unit; connect the 5 foot to "E" communication port of main modular unit; and connect the 3 foot to "Q" communication port of main modular unit. Wiring illustration as above.

Operation Description of LCD Touch Screen

The base conditions for using this LCD:

- 1) Voltage range: Input voltage: 24VDC±2%;
- 2) Power capacity: 15W,
- 3) Ambient temperature of using the LCD: 0°C÷50°C. Ambient temperature for keeping the LCD:

0°C÷ + 60°C. Ambient humidity for keeping the LCD: without frost 10%÷ 90%RH.

- 4 Displaying way: 7" TFT LCD
 Displaying color: 256 colors
 Resolution: 480×236 pixels
 LCD touch screen: Resistance type
 Defective proof level: IP 65

Function description:

This LCD control system is configured by the LCD of Air Cooled Heat Pump and outdoor unit electricity control system (At most 16 outdoor units could be connected). Configuration figure as follows:

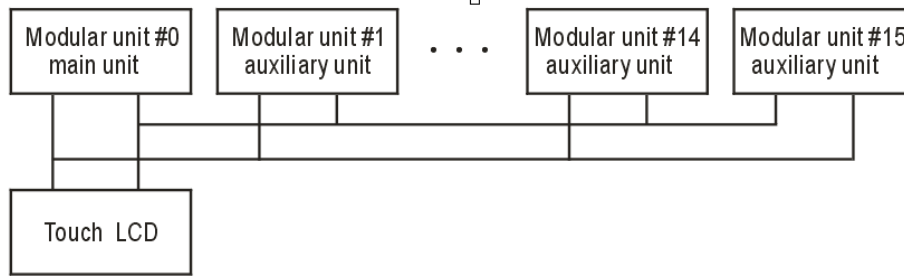

This LCD centralized control the Air Cooled Heat Pump Modular Chiller, delivers various control orders or setting functions to each unit system, as well as receives and displays operation data from units.

LCD operation window

The LCD Principal window as follows:

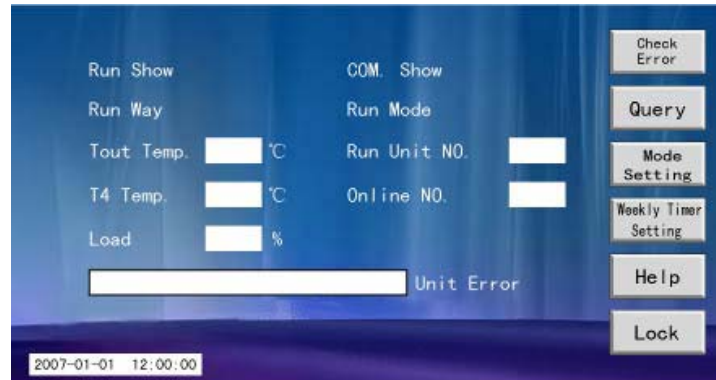

You could see the base information of the system in this principal window.

- 1) During operating, there are one or more modular units are in operating, dynamic circulation icons: [] [] [] are displaying, while shutdown the system, nothing is displayed.
- 2) During communicating with main modular unit in normal occasion, dynamic circulation displays blank or icons [] [] []. In case main modular unit communication is blocked, nothing will be displayed.
- 3) ×During the system in controlled by upper PC system, “System control on” is displayed, otherwise, nothing is displayed. (Reserve)
- 4) During the LCD screen in locking or LCD button in locking, “unlock” is displayed. While remove locking, “Lock” is displayed.

Query window

Click “query”, access to the following window:



In this page, you can query the information from unit No.0 to No.15.

On-line units' number shows in light blue, while out-line units' number shows in gray.

Page 1 of Query Window:

Press a certain on-line units' number, the following window shows and relevant parameters of the units system could be queried.

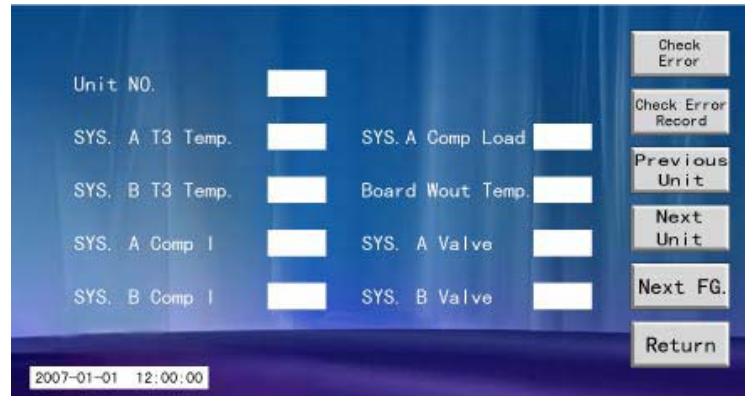

Page 2 of Query Window:

Press "Next FG." button, the other information of this unit group can be queried.

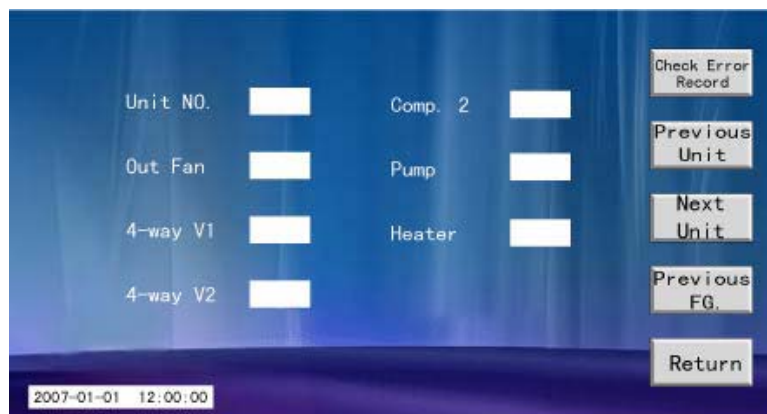

Press "Next unit" or "Previous unit" can query its neighbor unit's information.

LCD setting window.

Press "Mode setting" in principal window, the following window is entered.

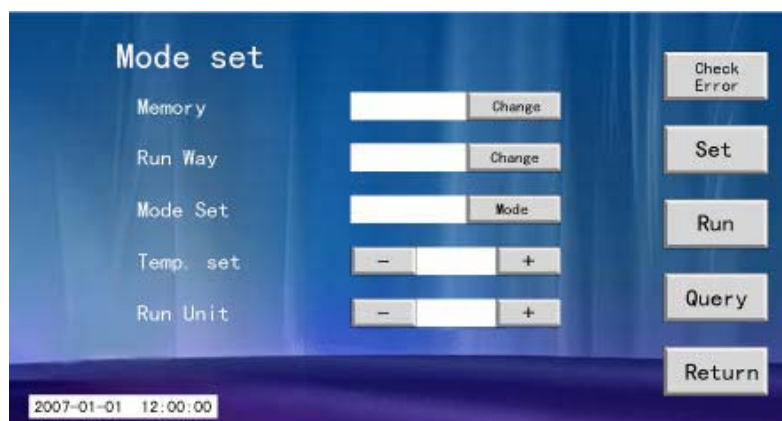

At this page, you could select Operation Mode and Control Mode, adjust temperature and set Power Failure Memory.

Temperature setting range: Cooling 7°C÷12°C, Heating 45°C÷ 50°C.

Malfunction queried window:

Press "Check Error" button at Query window or press "Check Error record" in principal window accessing to following window:



Malfunction occurring time and detail contents could be queried in this page. Click the malfunction in the form, and then click “Help” button, simple troubleshoot methods will be showed for user reference.

Error history window

In the page 1 of error history window, click “Check history record” button get in following window:

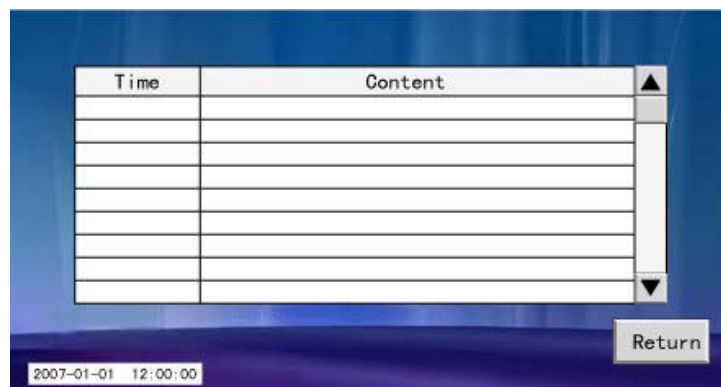

In this page, the ever occurred malfunctions and occurring times would be showed, however, once power failure, the malfunctions records would vanish.

Weekly timer setting window:

In this page, click “Weekly timer set” enters into following window:

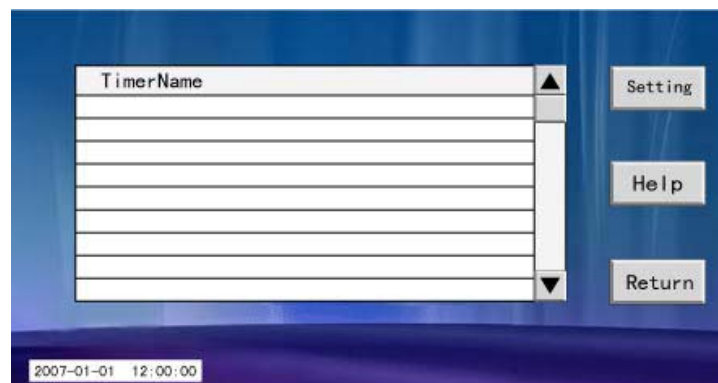

In this window, there are seven timing segments from “Time_set1” to “Time_set 7” for your setting. Click a timing segment, and then click “Setting”, enter to this time parameter setting, window as follows:

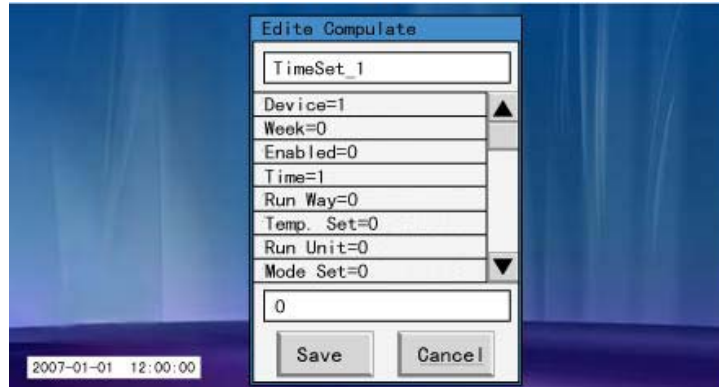

Electricity control function description

LCD operation description

Query function

Click “Query” button at principal window, and then enter to query window. The address codes of on-line units will show in this page in light blue. Click a light blue button, the page 1 of query window will be entered, click “Main FG” back to principal window. At the page 1 of “Query window”, click “Next Fig” could enter to other parameters setting pages; click “Next unit” or “Previous unit” could shift on-line units, click “Return” back to principal window; click “Check Error” or “Check Error record” button enter to malfunction query window, in which, you could check the detail of the malfunction, additionally, increase or decrease the units number's value could skips among the different units whose malfunctions could be showed. Selected a malfunction, and click “Help”, system will enter into troubleshoot window providing some malfunction remove methods for user. Click “Return” back to previous window.

Mode setting function

Click “Mode setting” in the principal window enter to Mode Setting window. Click “Run Way change” realizing the transition between Manual Control Mode and Auto Control Mode. When switch to “Auto” mode, run unit quantity will be shielded, i.e. in this mode, system will automatically decide the operating unit quantity as per capacity requirement, and drive up unit sequential according to their address from small to large. When switch to “Manual” mode, you should input the quantity to “Run unit” (Such value cannot larger than actual connected unit's quantity within the system.)

If the system already in operating, any set are unavailable, but shutdown, because operation cannot be changed during operating.

If the system in close-down, press the “Mode set” button, the mode would be changed once a time, the mode changed sequence as follows:

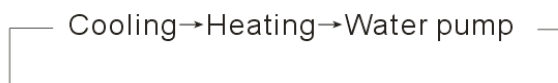

Under cooling mode operation, click temperature decreasing key to decrease temperature, once a degree, default temperature is 7°C. Cooling adjusted temperature range is 7°C ÷ 12°C

Under heating mode operation, click temperature increasing key to increase temperature, once a degree, default temperature is 45°C. Heating adjusted temperature range is 45°C ÷ 50°C

Under water pump mode, temperature adjusted keys will be shielded.

In this page, you could query or return to previous page.

Locking function

If the LCD touch screen without be locked by upper PC or by keys, “Lock” is display in the upper left in the screen, click “Lock” then will be noticed to input user's name and password, after that, screen will be locked, “Unlock” is display.

If the LCD touch screen be locked by upper PC or by keys, “Unlock” is display in the upper left in the screen, click “Unlock”, the screen is unlocked, “Lock” is display.

When LCD or key is locked, all functions operations are invalid, but Query, System Setting and Help functions are excepted.

Run/Stop button

At Mode Setting window, Stop button is available when unit operating, while Run button that shielded by Shielded Mode will unavailable though be shifted. Run button is available when unit standbys, all buttons are available but Stop button.

Unit is closed down when system in operating, and it will run according to last mode (Includes operation mode and manual/auto control mode) till to the next start-up, but the start-up mode or control mode have been reset.

Run/Stop button are available in anytime. Every time you press this key, which is unavailable at once until the operation order have been sent out (cost no more than 5 seconds).

Temp. Set button

After setting up “Temp. Set” at heating or cooling mode, press “Set” button to confirm the finish of temperature setting.

Communicate with unit group

Provided that LCD without receive data from main modular unit last than 10 seconds, that means main modular unit communication malfunction is occur, and “Equipment communication have blocked” is displayed in the screen. Malfunction could be removed when communication is recovery. If communication data error occurs in main modular unit or auxiliary unit, which means communication malfunction between LCD and modular unit is come out, error code “ED” shows, which could be removed when communication is recovered.

Communicate with upper PC (Reserve)

LCD in receiving status at normal occasion, waiting for receives data from upper PC.

If LCD receives data from upper PC, unit is in network controlling, “Network control ON” displays. If no signal receives from upper PC last than 1 second that means unit exit from network controlling and “Network control ON” disappear. If frame error or data verified error comes out during data communication that means communication malfunction between LCD and PC is put out, code “EE” shows, it will recovery after malfunction be removed.

Operation mode and control mode setting

Select “Mode Setting” window by the key in principal window, and then select “Run Way” and required “Run Unit” quantity in the mode setting window.

- 1) When “Auto” control mode is selected, operation mode and control mode in there are stand for the modes of whole unit group system, thus you don't need to selected the” Run Unit” quantity that has been defined as the actual on-line unit quantity. The actual operating unit quantity is decided by electricity control of main modular unit.
- 2) When “Manual” control mode is selected, such operation mode and control mode are stand for the current selected unit, and “Run Unit” quantity could be altered. Once click “Run Unit”, actual operating unit quantity is decided by LCD. Units will be driven up sequential according to their address from small to large till to the set quantity is satisfied. While they will close off sequential according to their address from large to small till to the set quantity is satisfied.
- 3) Only the pump in main modular unit will open, when open Pump Mode at manual control mode. Main modular unit cannot be taken place of another, provided that malfunction is come out from it.

Malfunction alarm disposing

In case protection or malfunction comes out, the corresponding malfunction unit's number will display in the principal window. User could check malfunction detail via Query Function.

In case main modular unit come out of malfunction, all units within this modular would close down according to their address code value from large to small. Unit will return to work in normal when restarted by main modular unit or LCD until malfunction has been settled out.

Power failure memory

- You could select this function manually in LCD. When this function is shielded, system will not read and save parameters.
- The set parameters in memorizer. (Operation Mode: Cooling or Heating or Pump mode; Run Way: Manual or Auto mode; Temperature setting; Run/Stop: Unit Run or Unit Stop; Lock or Unlock, etc.) When power be input at the first time, reading of set parameter as zero.
- Once open the power failure memory function, memorizer will record the latest parameter setting, through is different from previous setting.

Timing ON/OFF function

Time parameters in this function are take the time displayed in LCD as a standard, applying weekly timer to realize.

There are seven time segments for your selection in Time Setting window, from time_1 to time_7, and there are 9 parameters needed to be set under each segment, which are:

Device=1(Keep default as 1, don't alter it.)

Week=0(User could input 0~7, 1~7 are represent from Mon. to Sun., 0 stand for everyday)

Enabled=0(1 stand for weekly timer is available, 0 stand for weekly timer is unavailable)

Time=00:00(User could input anytime from 00:00 to 24:00)

Run Way=0(0 stand for Auto, 1 stand for Manual)

Temp. Set=0(Cooling temperature from 7°C ÷ 12°C, Heating temperature from 45°C ÷ 50°C)

Run Unit=0(At manual control mode, operating unit quantity shall not be chosen exceeding than on-line unit quantity, otherwise, system run abnormally or auto mode inefficiency)

Mode Set=0(1 stand for Cooling mode, 2 stand for Heating mode and 3 Stand for Pump mode; Shutdown the unit shall be set as 0.)

On Off Set=0 (0 stand for shut-down, 2 stand for start-up)

16 Annex:**- OHMIC VALUE OF TEMPERATURE SENSOR [°C] E [kΩ]**

T(°C)	R (kΩ)	T(°C)	R (kΩ)	T(°C)	R (kΩ)	T(°C)	R (kΩ)
-20	115.266	20	12.6431	60	2.35774	100	0.62973
-19	108.146	21	12.0561	61	2.27249	101	0.61148
-18	101.517	22	11.5000	62	2.19073	102	0.59386
-17	96.3423	23	10.9731	63	2.11241	103	0.57683
-16	89.5865	24	10.4736	64	2.03732	104	0.56038
-15	84.2190	25	10.000	65	1.96532	105	0.54448
-14	79.3110	26	9.55074	66	1.89627	106	0.52912
-13	74.5360	27	9.12445	67	1.83003	107	0.51426
-12	70.1698	28	8.71983	68	1.76647	108	0.49989
-11	66.0898	29	8.33566	69	1.70547	109	0.48600
-10	62.2756	30	7.97078	70	1.64691	110	0.47256
-9	58.7079	31	7.62411	71	1.59068	111	0.45957
-8	56.3694	32	7.29464	72	1.53668	112	0.44699
-7	52.2438	33	6.98142	73	1.48481	113	0.43482
-6	49.3161	34	6.68355	74	1.43498	114	0.42304
-5	46.5725	35	6.40021	75	1.38703	115	0.41164
-4	44.0000	36	6.13059	76	1.34105	116	0.40060
-3	41.5878	37	5.87359	77	1.29078	117	0.38991
-2	39.8239	38	5.62961	78	1.25423	118	0.37956
-1	37.1988	39	5.39689	79	1.21330	119	0.36954
0	35.2024	40	5.17519	80	1.17393	120	0.35982
1	33.3269	41	4.96392	81	1.13604	121	0.35042
2	31.5635	42	4.76253	82	1.09958	122	0.3413
3	29.9058	43	4.57050	83	1.06448	123	0.33246
4	28.3459	44	4.38736	84	1.03069	124	0.32390
5	26.8778	45	4.21263	85	0.99815	125	0.31559
6	25.4954	46	4.04589	86	0.96681	126	0.30754
7	24.1932	47	3.88673	87	0.93662	127	0.29974
8	22.5662	48	3.73476	88	0.90753	128	0.29216
9	21.8094	49	3.58962	89	0.87950	129	0.28482
10	20.7184	50	3.45097	90	0.85248	130	0.27770
11	19.6891	51	3.31847	91	0.82643	131	0.27078
12	18.7177	52	3.19183	92	0.80132	132	0.26408
13	17.8005	53	3.07075	93	0.77709	133	0.25757
14	16.9341	54	2.95896	94	0.75373	134	0.25125
15	16.1156	55	2.84421	95	0.73119	135	0.24512
16	15.3418	56	2.73823	96	0.70944	136	0.23916
17	14.6181	57	2.63682	97	0.68844	137	0.23338
18	13.9180	58	2.53973	98	0.66818	138	0.22776
19	13.2631	59	2.44677	99	0.64862	139	0.22231

- PRELIMINARY INSTRUCTIONS TO INSTALL DIGITAL CHILLER UNIT



- Clean accurately all piping system both for new and old plants before switching on the unit.
 - Place Master unit MGA-D as first unit before plant and then place slave unit behind master unit.
 - Water pump discharge must be the inlet for master unit.
 - Electronic control must be placed in dry place (within 1200 meters from master unit)
 - Good working is guaranteed if expansion tank, Y shape filter, security valve (3 bars), air purges, water flow switch or differential pressure switch, pressure gauges and thermometers , on/off valves are installed.
 - Connect modules with accessories supplied by constructor: iron connections, soft rubber connections between two units and ahead first unit, stemmed flanges, rubber shock absorbers.
- Electric connection between master unit, slave unit and wire controller must be done with 2 wires (P,Q) and shielded wire bus(E).

- LAYOUT AND RESPECTED SPACE

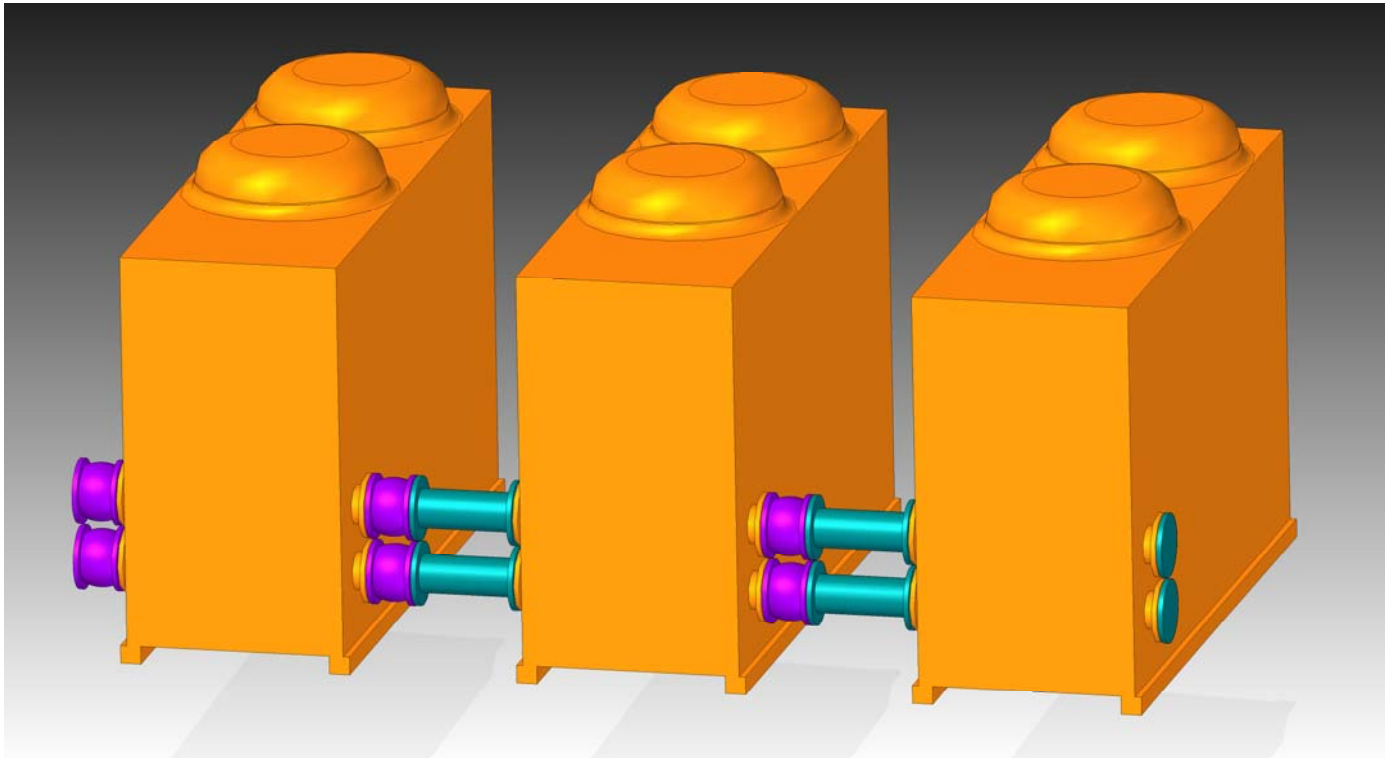

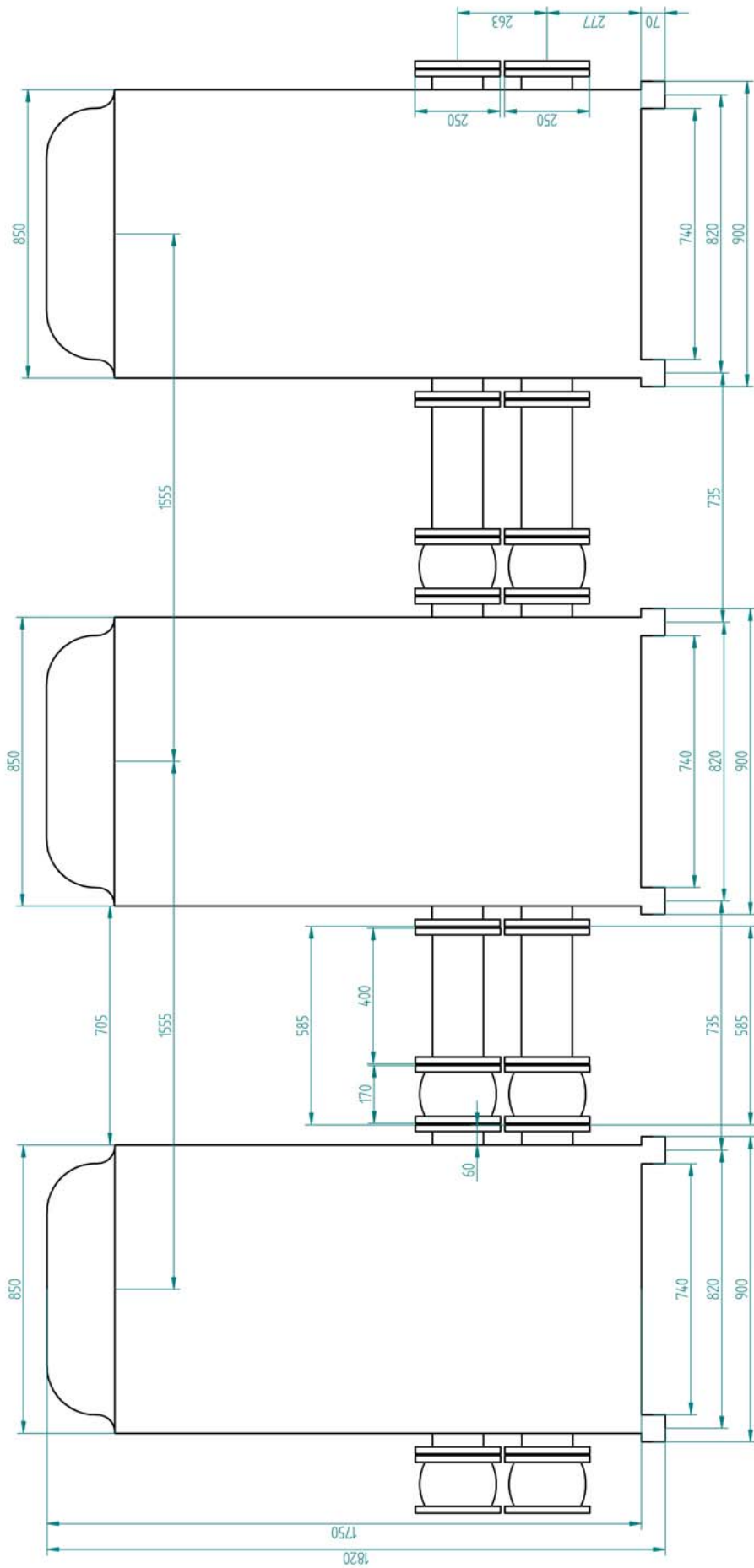



A2B Accorroni E.G. S.r.l. - Via d'Ancona, 37 - 60027 Osimo (An)
Tel. 071.723991 - Fax 071.7133153 - Web Site: www.accorroni.it - E-mail: a2b@a-2-b.it